

# SealBoss®

## IP495 Injection Pump



Product Data Sheet

Injection System

Professional Grade Electric Piston Pump

### SealBoss® IP495 Injection Pump

- Pressure Controlled
- Pressure Preadjust Knob
- Automatic Shut-Off
- Single Component
- 3000 PSI, 210 BAR
- Piston System
- Suction Tube
- Mounted on Stand
- Reliable, Easy to Use, Easy to Clean
- Connects to a Wide Range of Packers
- Works with Many Materials

### SealBoss® Recommended Products

- SealBoss 1510 Water Stop Foam
- SealBoss 1570 Flexible Foam
- SealBoss 1570 LV Low Viscosity Foam
- SealBoss 1403 SLV Resin
- SealBoss FlexGel Hydrophilic PU Gel
- R 70 Pump Flush Cleaner | Conditioner

More Information | Scan QR Code:

- Videos
- Product Links



The **Sealboss® IP495 Injection Pump** is a lightweight and powerful injection pump, customized and modified by SealBoss® and can be used for most of the SealBoss® polyurethane and epoxy injection line products with viscosities between 10 and 800 cps. Call your SealBoss® technician for details.

The pump features a pressure gauge and product output assembly designed to connect securely to the **SealBoss® High Pressure Hose Set** including high quality shut-off valve and coupler. The Hose Set is available in varying lengths and sold separately. The Hose set can be equipped with either a standard SealBoss (4 prong) Zerk Coupler or with the SealBoss Button Head Slide Coupler for use with the extensive SealBoss Mechanical Injection Packer System.

Equipped with pressure gauge and a large control button for injection pressure adjustments, the pump automatically shuts-off when the desired pressure is reached and restarts pumping when the pressure drops. This feature speeds up the injection process, keeps noise levels at a minimum and prolongs the life of the motor and mechanical parts.

Recommended use: Small to large injection jobs, frequent injection jobs.

### Technical Data

System:	Displacement Pump
Max Pressure:	3000 psi
Weight:	34 lb, 15.4 kg
Power:	0.75 HP DC Motor, 120 VAC, 60 HZ, 15A
Delivery:	~0.5 gpm, ~1.9 l/min
Max Hose Length:	~330 ft (100 m)



Hose extension with valve and packers sold separately

**Ask for our "Starter Kit" Option**

SealBoss® IP495 Injection Pump



### Parts List

1. Screw
2. Pressure Control Knob
3. Pressure Control Knob Bottom
4. Pressure Switch
5. Transducer Assembly
6. Upper Bushing
7. Upper Packing
8. Front Cover
9. Screw (3)
10. Outlet Fitting
11. Yoke Assembly
12. Retainer Ring
13. Washer
14. Dowel Pin
15. Screw
16. Seal
17. Filter Assembly
18. Filter Housing
19. Return Tube Fitting
20. Piston Assembly (Items 20-24)
21. Upper Cage
22. Outlet Valve Ball
23. Outlet Valve Seat
24. Outlet Valve Retainer
25. Lower Packing
26. Bushing
27. Inlet Valve Cage
28. Inlet Valve Seal
29. Inlet Valve Ball
30. Inlet Valve Seat
31. O-Ring, PTFE
32. Inlet Valve Housing

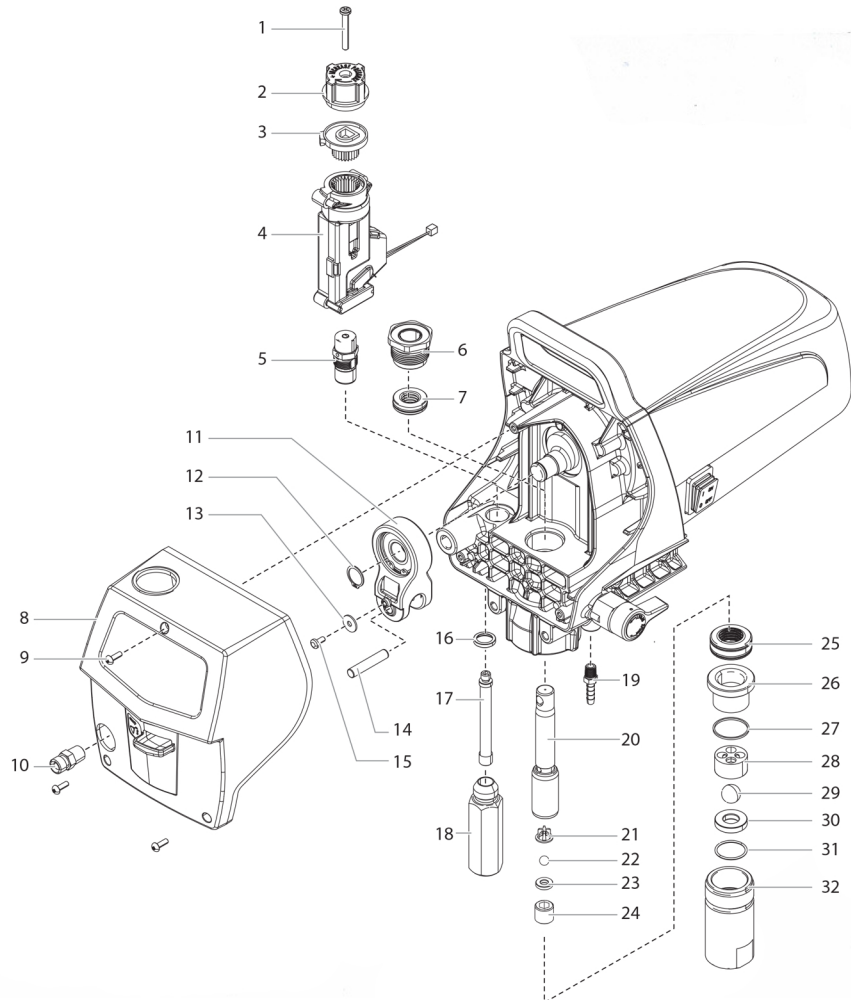

More Information | Scan QR Code:

- Videos
- Product Links



**Limited Warranty Policy and Disclaimer for Products Supplied and/or Distributed by SealBoss Corp.:** SealBoss Corp. Products are for Professional Use. All recommendations, statements and technical data herein are based on tests we believe to be reliable and correct, but accuracy and completeness of said tests are not guaranteed and are not to be construed as a warranty either expressed or implied. User shall rely on his or her own information and tests to determine suitability of the product for the intended use and user assumes all risk and liability resulting from his or her use of the product. Nothing contained in any supplied materials relieves the user of the obligation to read and follow the warnings and instruction for each product as set forth in the current Technical Data Sheet, product label and Safety Data Sheet prior to product use. SealBoss Corp. warrants supplied / distributed products to be free of manufacturing defects. Seller's and manufacturer's sole responsibility shall be to replace that portion of the product of the manufacturer which proves to be defective. There are no other warranties by SealBoss Corp. of any nature whatsoever expressed or implied, including any warranty of merchantability or fitness for a particular purpose in connection with this product. SealBoss Corp. shall not be liable for damages of any sort, including remote or consequential damages resulting from any claimed breach of any warranty whether expressed or implied. SealBoss Corp. shall not be responsible for use of this product in a manner to infringe on any patent or any other intellectual property rights held by others. In addition, no warranty or guarantee is being issued with respect to appearance, color, fading, chalking, staining, shrinkage, peeling, UV damage, excessive temperature exposure, normal wear and tear or improper application by the applicator. Damage caused by abuse, neglect and lack of proper maintenance, acts of nature and / or physical movement of the substrate or structural defects are also excluded from the limited warranty. SealBoss Corp. reserves the right to conduct performance tests on any material claimed to be defective prior to any repairs by owner, general contractor, or applicator. Neither seller nor manufacturer shall be liable to the buyer or any third person for any injury, loss or damage directly or indirectly resulting from use of or inability to use the product. Recommendations and statements other than those contained in a written agreement signed by an officer of the manufacturer shall not be binding upon the manufacturer or seller. SealBoss Corp. reserves the right to change the properties of products without notice.

Revised 202008