

Installation Procedure

Last Updated: April 13th, 2018

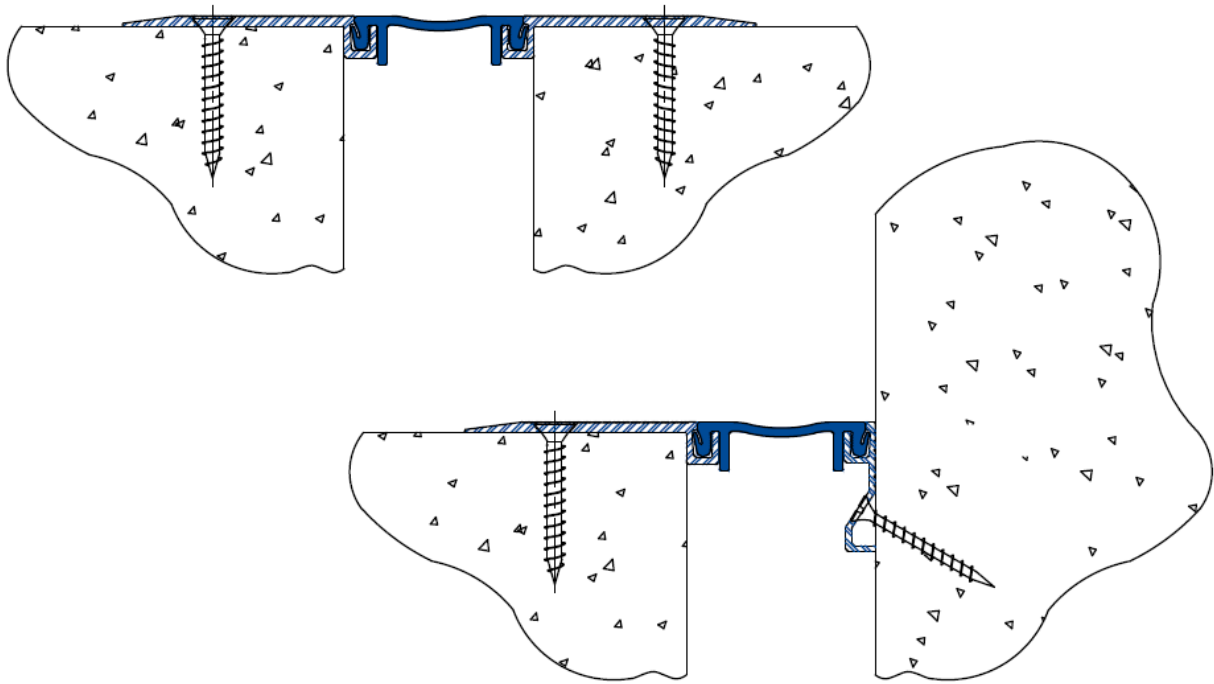

Wabo® CorridorWrap, “CWWM” & “CWWM-C” Vertical Expansion Joint System

The following installation procedure is very important and must be fully understood prior to beginning any work. To ensure proper installation and performance of expansion joint system the following actions must be completed by the installing contractor. Failure to do so will affect product warranty.

- 1) Carefully read and understand installation procedure. Contact WBA's Technical Service Department at (800) 677-4922 for product assistance.
- 2) Inspect all shipments and materials for missing or damaged components and hardware. Contact Customer Service at (800) 677-4922 with WBA's order number and invoice for prompt assistance.
- 3) Inspect substrate or adjacent construction for acceptance before beginning work. Report unacceptable construction to the project manager for scheduled repair work.
- 4) Review WBA shop drawings for project specific detailed information if Engineering services were purchased at time of order.

Information provided herein, including but not limited to, any drawing, design, photograph, graphic, or statement(s) ("Materials") are proprietary and the property of Watson Bowman Acme Corp. ("Company"). Reproduction, translation, or reduction to any electronic medium or machine readable form, in whole or part, is strictly prohibited, except for the express purpose for which it has been furnished, without prior written consent of Company. All Materials contained herein are provided by Company for information purposes only. Company reserves the right to amend or withdraw any information contained in the Materials without notice. All technical or other advice by Company, whether verbal or written, concerning products, or the use of products in specific situations ("Advice") is given by Company and is used at the User's own risk.

Health & Safety

During the installation of any Watson Bowman Acme product, appropriate personal protective items should be worn at all times, including but not limited to the following:

- Proper work clothing
- Safety glasses
- Safety boots
- Gloves
- Hard hat



Local rules and regulations regarding safe work environments and health should be followed.

Product Components

The following components are required for the installation of this product:

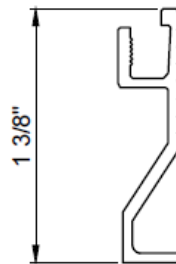

* CWWS Corner Wall Mount
Aluminum Extrusion P/n: 20401

Components shown below vary in size depending on model of system:



241F Adhesive, P/n:
2716



PP Primer for 241F
Adhesive, P/n: **2717**

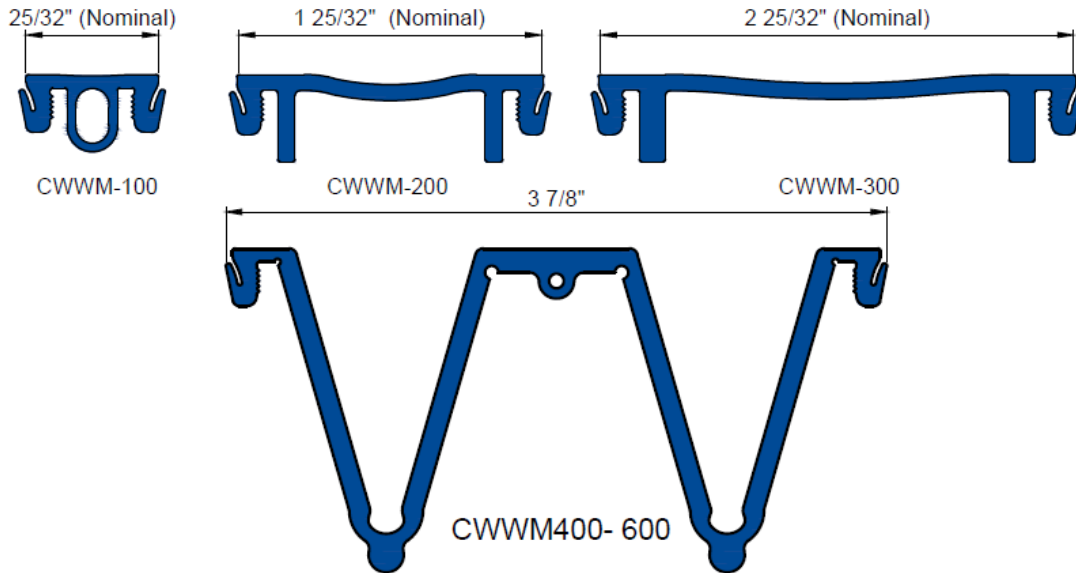

Part Number				
Model	Black Seal	White Seal	Beige Seal	Grey Seal
CWWM-100/100C	17501	17504	17503	17502
CWWM-200/200C	17605	17608	17607	17606
CWWM-300/300C	17705	17708	17707	17706
CWWM-400/400C	17401	17404	17403	17402
CWWM-500/500C	17401	17404	17403	17402
CWWM-600/600C	17401	17404	17403	17402

~ Optional components for splice procedures. Place order for required quantities.
 * Components required for corner condition

Installation (Wall-to-Wall)

- 1 Prior to beginning work, installer shall inspect for proper wall construction. Verify joint opening is as called for on chart.

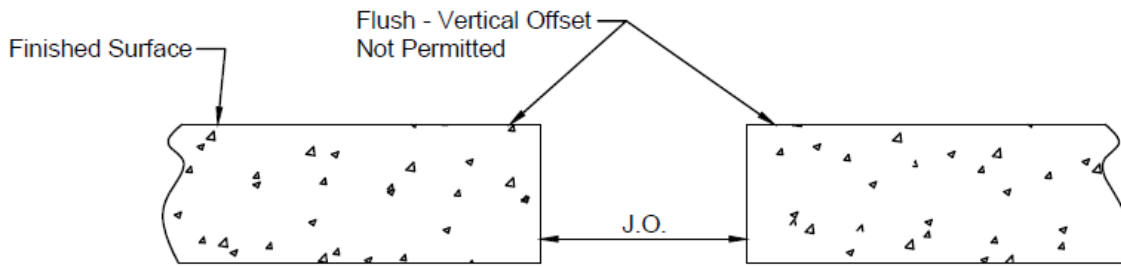

Typical Section
Wall to Wall

Dimension chart

Model	"J.O."
CWWM-100	1"
CWWM-200	2"
CWWM-300	3"

- 2** Place aluminum wall extrusion on edge of opening as shown. Utilizing drill bit, drill through extrusion, and into stud. Fasten with anchors (by contractor) spaced at 24" o.c. maximum, start 6" from ends.

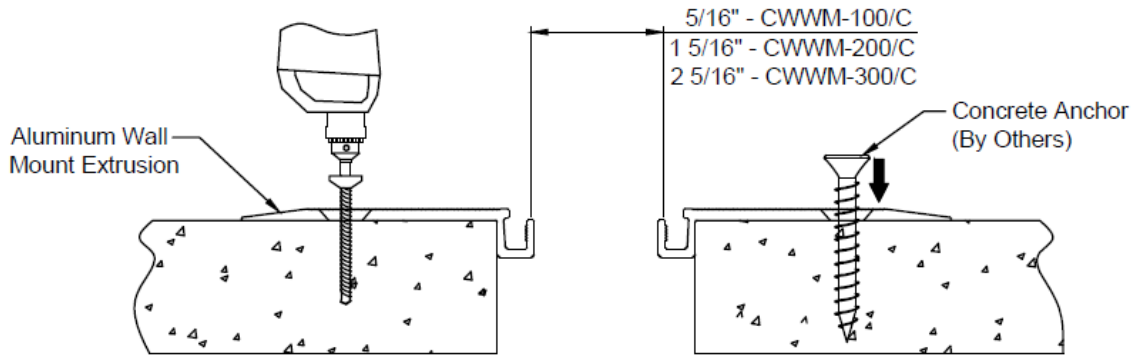

- 3** After completing installation of aluminum wall extrusion, snap lugs of seal into extrusion cavity on both sides of the joint .

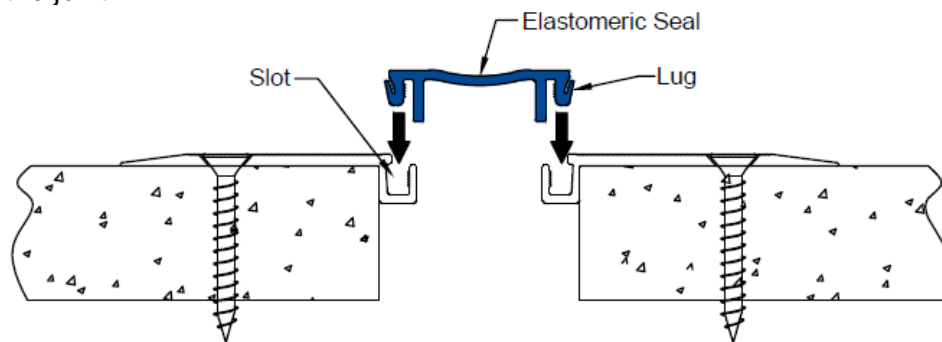

Installation (Corner Condition)

- 1** Prior to beginning work, installer shall inspect for proper wall construction. Verify joint opening is as called for on chart.

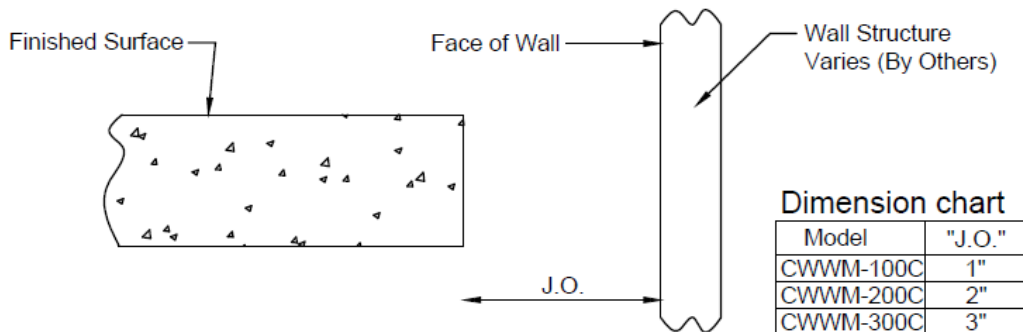

- 2** For installation of Wall Mount Aluminum Extrusion, utilize a suitable anchor (By Others) spaced at 24" Max. O.C. based upon the wall construction.
Note: Wall Mount Extrusion is not pre-drilled by the manufacturer.

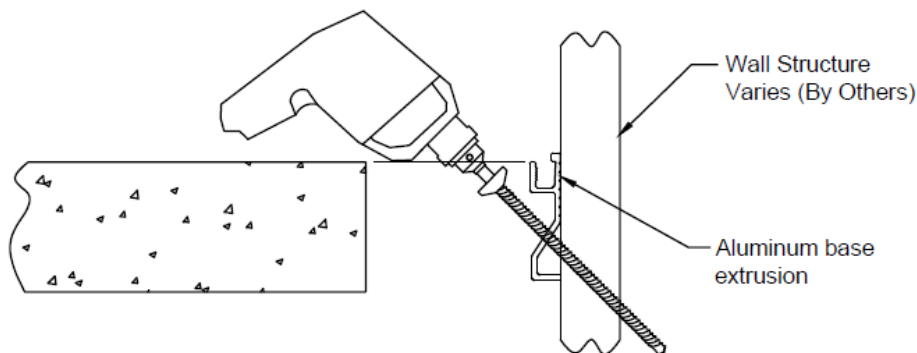

- 3** After completing installation of aluminum corner extrusions, install aluminum wall extrusion according to flush wall instructions.

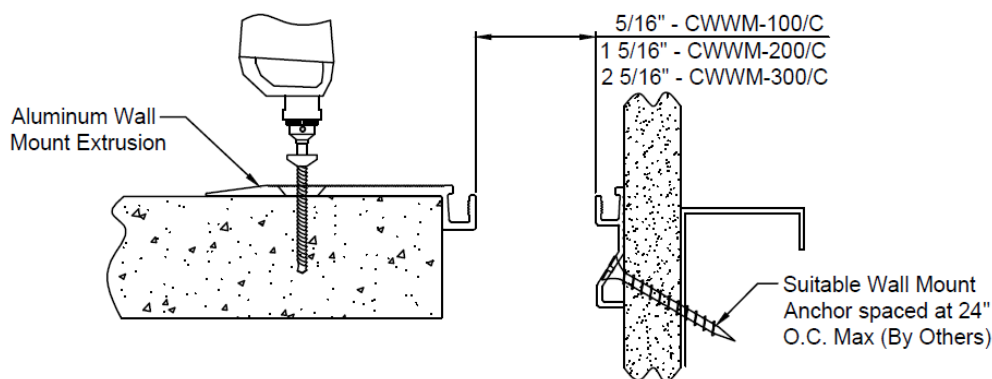

- 4** Insert Elastomeric Seal into slots of the Aluminum Base Extrusion, exercising care not to damage Elastomeric Seal.

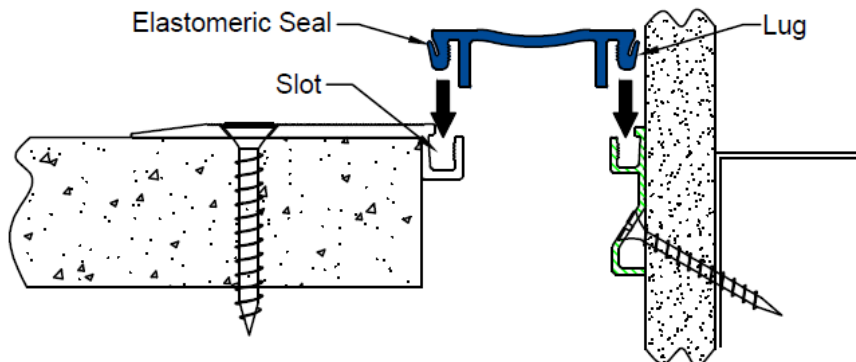

5

Finished view.

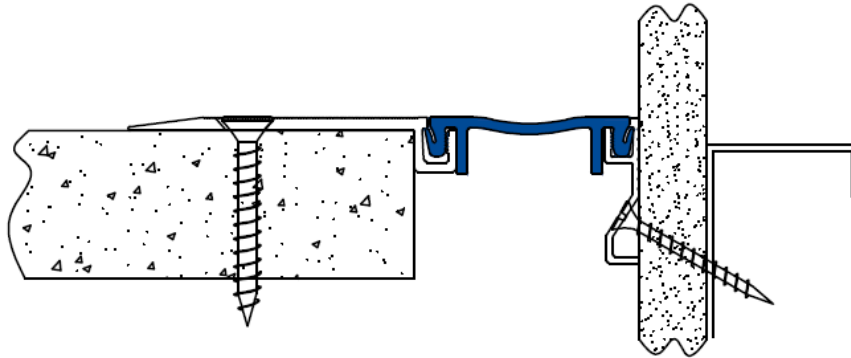

Suggested Field Splice Procedure

1. Cut ends of seal with a sharp knife and miter box to the desired angle. Ensure that cuts are clean and straight.
2. Clean ends of seal with a solvent.
3. Brush apply PP Primer to both seal ends to be joined.
4. Apply 241F Adhesive to one of the two seal ends to be bonded.
5. Apply pressure, bringing the two surfaces into tight contact immediately after adhesive is applied. Hold in place for one to two minutes for initial bond.
6. Re-check quality of all splices/miters and apply adhesive as required.
7. It is usually recommended to allow 15 minutes prior to installing seal. To achieve proper working strength, care shall be exercised since it takes 24 hours for adhesive to fully cure.



241F Adhesive



PP Primer

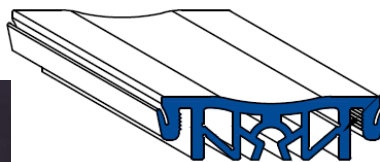

Surface to be spliced.
Note: Make sure that internal webs match to ensure good adhesion.

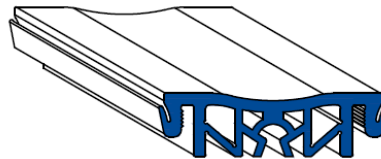

Follow us on social media for industry news, new product announcements & more:

