

MILE HIGH FOAM®

CLOSED CELL POLYURETHANE

TECHNICAL DATA SHEET

1. Product Name: **MILE HIGH FOAM®**
2. Exclusively Sold By: **Backer Rod Mfg. Inc.**
4244 N Broadway
Denver, CO 80216
Phone: 800-595-2950
Fax: 303-308-0393
Website: www.backerrod.com

3. Product Description:
Per ASTM C 1330 type C **Mile High Foam®** is a resilient, polyethylene backer rod used as a backing material for cold applied elastomeric caulking sealants. Mile High Foam® controls the depth of the sealant installation and ensures cross – sectional hour-glass configuration. No bond breaker is required.

Specific Uses:

- Expansion joints
- Highway joints
- Glazing
- Log home chinking
- Parking Decks
- Curtain walls
- Coping joints
- Isolation joints
- Temporary joint seal

4. Composition and Material:

Mile High Foam® is a round, black, resilient, extruded closed cell polyethylene backer rod with a water resistant outer skin. It is compatible with most known cold applied sealants such as urethane, silicone, acrylic, butyl, polysulfide, latex, and log chinking sealants.

5. Installation:

Joint openings must be free of all contaminants, loose materials, dry and free of frost. Select correct rod size for joint width. With a blunt instrument or roller, seat rod to depth recommended by sealant manufacturer.

6. Compatibility:

Mile High Foam® is chemically inert and will resist gasoline, oil, and most solvents. Product will not stain or adhere to sealants.

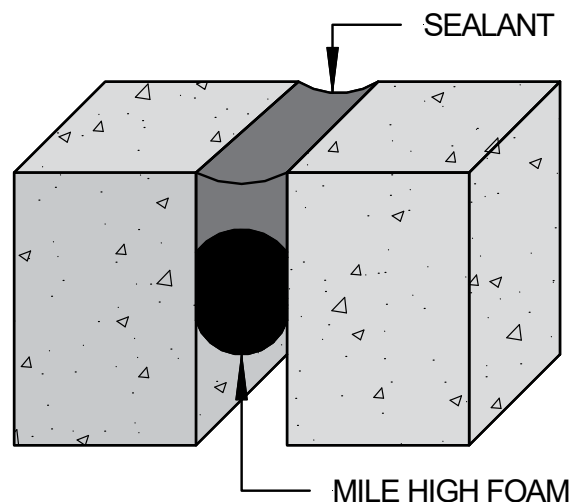

7. Physical Properties:

Physical Properties		
Property	Value	ASTM Test Method
Density (Normal)	1.25 - 2 lb/ft ³	D 1622
Out-gassing	> 1	C 1253
Compression Recovery	>90	D 5249
Tensile Strength PSI	39 - 50 psi	D 1623
Temperature Range	-90° F to 210°F	D 5249
Water Absorption	0.002 g/cm ³	C 1016 - Proc. B



8. Packaging Information

Packaging Information						
Linear Feet Per Unit/ (metric)				Weight & Measurements		
Diameter	Mini Box	Standard Box	Super Box	Mini Carton	18-1/4" x 18-1/4" x 15"	7 lbs ea.
1/4" (6mm)	3200 (975m)	6400 (1951m)		Standard Carton	18-1/4" x 18-1/4" x 30-1/2"	10 lbs ea.
3/8" (10mm)	1800 (548m)	3600 (1097m)				
1/2" (13mm)	1250 (381m)	2500 (762m)				
5/8" (16mm)	775 (236m)	1550 (472m)		Super Carton	18-1/4" x 18-1/4" x 74-1/4"	14 lbs ea.
3/4" (19mm)	550 (167m)	1100 (335m)				
7/8" (22mm)		850 (257m)		Mini Carton		• 1 spool per carton
1" (25mm)		550 (168m)				
1-1/4" (32mm)		400 (122m)		Standard Carton		• 1/4" through 3/4" 2 spools per carton • 7/8" through 1-1/4" 1 spool per carton
1-1/2" (38mm)			420 (128m)			
2" (51mm)			252 (77m)			
2-1/2" (63mm)			162 (49m)	Super Carton		• 1-1/2" through 4" manufactured in 6' lengths
3" (76mm)			102 (31m)			
4" (102mm)			54 (16m)			

9. Limitations

Do not use with hot applied sealants. Do not puncture, over compress or stretch **MILE HIGH FOAM®** during installation.

10. Availability and Cost

MILE HIGH FOAM® is marketed nationally and internationally by select authorized distributors. For name, address and telephone number of your nearest distributor please contact us at: 800-595-2950 or sales@backerrod.com

11. Warranty

Unless otherwise agreed to in writing, **MILE HIGH FOAM®** is sold without warranty, express or implied. Buyer must make their own determination as to the suitability of the product and application. Sizes and lengths of products shown are at time of packaging and will vary with climate conditions after manufacture.

12. Technical Services

Please contact Backer Rod Mfg. Inc. for technical guidance, special project engineering designs and drawings.

PRODUCT INFORMATION SHEET

MILE HIGH FOAM® CLOSED CELL POLYETHYLENE FOAM BACKER ROD

IMPORTANT INFORMATION: Flexible polyurethane is an “article”, not a chemical, as defined in 29 CFR 1910.1200©. It does not require a Safety Data Sheet under OSHA’s Hazard Communication Standard. As a service to our customers, however, Backer Rod Mfg. Inc. has produced this Product Information Sheet.

SECTION 1 - PRODUCT AND COMPANY IDENTIFICATION

Date of Preparation: August 1, 2018
Product Name: Mile High Foam® closed cell polyethylene backer rod
Other Names: Closed cell low density polyethylene foam (LDPE)
Manufacturer Name: Bay Foam Products
2240 West Peoria Ave
Phoenix, AZ 85029
602-943-4151
www.bayfoamproducts.com

SECTION 2 - PHYSICAL AND CHEMICAL CHARACTERISTICS

Since flexible polyethylene foam is a solid, physical characteristics such as boiling point, vapor pressure, vapor density evaporation rate, etc., do not apply.

Appearance: Cellular flexible material, light brown in color. May also be in various colors.
Density: 1.25 - 2lbs per cubic foot
Solubility in Water: Insoluble
Stability & Reactivity: Stable. No hazardous polymerization will occur in normal use.
Prolonged exposure to temperatures in excess of 196°F may cause some loss of volatile components (e.g., flame retardants) through evaporation.
Unprotected polyurethane foam will discolor and degrade under prolonged exposure to UV light.
Solvent resistance will vary with solvent type.

SECTION 3 - FIRE HAZARD INFORMATION

Auto-Ignition Point: 343°F (ASTM D1929)

SECTION 3 - FIRE HAZARD INFORMATION CONTINUED

- Fire Hazard:** **WARNING: Polyethylene Foam will burn if exposed to an open flame or other sufficient heat source. Do not expose polyethylene foam to open flames or any other direct or indirect high temperature ignition source such as burning operations, welding, space heaters, or naked lights**
- Once ignited, polyethylene foam will burn rapidly, releasing great heat and consuming oxygen at a high rate. In an enclosed space the resulting deficiency of oxygen will present a danger of suffocation to the occupants. Hazardous gasses released by the burning foam can be incapacitation or fatal to human beings if inhaled in sufficient quantities.**
- Once ignited, polyethylene foam is difficult to extinguish. Foam fires that appear to be extinguished may smolder and re-ignite. Always have fire officials determine whether a fire has been extinguished.**
- Piles of foam dust can be readily ignited and present a potential fire hazard. High concentrations of foam dust in the air can be a potential explosion hazard if exposed to flames, sparks, or other ignition sources.
- Extinguishing Media:** Water spray, dry chemical, foam of carbon dioxide
- Fire-fighting Protection:** Fire-fighting personnel must be equipped with a self-contained breathing apparatus (SCBA) and fire-fighting clothing.
-

SECTION 4 - HEALTH HAZARDS

- Exposure Limits:** None Established
- Acute Toxicity:** Skin Absorption - Not likely, Non-irritating
- Swallowing - None determined
- Inhalation - Inhalation of foam dust may cause irritation to nose, throat, and lungs.
- Skin Contact - Non-irritating
- Eye Contact - Foam dust may cause eye irritation or injury
-

SECTION 5 - HANDLING AND STORAGE

Keep foam away from sparks, naked lights, open flames, exposed electrical elements, or other ignition sources. Smoking should be forbidden in areas where material is stored or processed.

Maintain adequate sprinkler protection where large volumes of foam are kept (e.g. warehouse, fabrication areas and storage rooms). Check for compliance with insurance regulations, local building codes or other legal requirements.

Never use foam as an exposed interior wall or ceiling finish

Maintain sufficient aisle space to permit access for fire-fighting equipment and personnel to all foam storage areas.

Do not allow cutting or foam scrap to accumulate

Be aware that terms sometimes used to describe polyethylene foam, like "fire-retardant" and "flame resistant", do not mean fire safety under all conditions. Flammability ratings from small-scale laboratory tests are not to be taken as an indication of the materials behavior under actual fire conditions.

SECTION 6 - PERSONAL PROTECTION AND EXPOSURE CONTROLS

Protective Equipment: Unless exposure to foam dust is anticipated, dust masks, goggles, and gloves are not required. Long sleeves are recommended if arms are repeatedly rubbed against foam.

Ventilation: Mechanical ventilation should be considered in operations that generate abnormal quantities of foam dust, or where thermal decomposition of the foam occurs (e.g. hot-wire cutting, heat sealing, hot stamping and flame laminating).

SECTION 7 - EMERGENCY AND FIRST AID PROCEDURES

Skin: Wash off any foam dust.

Eyes: Flush thoroughly with water.

Ingestion: None necessary unless throat is obstructed

Inhalation: Consult physician if coughing, discomfort, or obstruction of air passage occurs.

The information presented here is offered for your consideration, investigation and verification. The information is presented in good faith and was obtained from sources Bay Foam Products Inc. believes to be reliable. Bay Foam Products Inc., however, makes no representation as to the completeness and accuracy. Bay Foam Products Inc. makes no warranty, express or implied, with respect to the information contained herein.

Bay Foam Products Inc. cannot anticipate all conditions under which this information and the product may be used. The conditions of handling, storage, use and disposal of the product are beyond Bay Foam Products Inc.'s control. Thus, we expressly disclaim responsibility or liability for any loss, damage or expense arising out of reliance on the information contained herein. You are advised to make your own determination as to safety, suitability and appropriate manner of handling, storage, use and disposal.