

# SpecSeal<sup>®</sup> Series SSW Wrap Strip Collar

General: In most cases, walls require symmetrical applications and wrap strips must be applied to both sides. Wrap strips may be continuously wrapped or installed individually around the penetrant. When multiple layers of a wrap strip are installed individually, butted ends in successive layers may be aligned or offset. When selecting a wrap strip grade, refer to TABLE B.

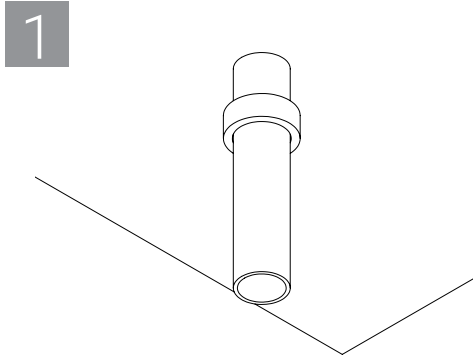

1  
Apply Wrap Strip around penetrant, ends held together with foil tape. See appropriate UL System for required number of wrap strip stacks and layers.

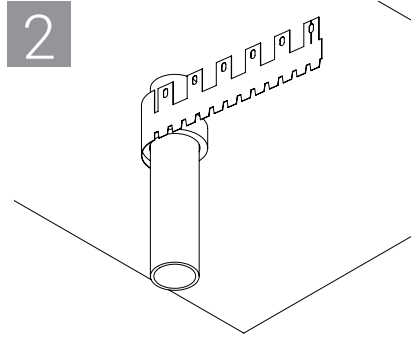

2  
Encircle Wrap strip layers with restraining steel having a 1" lap. See Product Data Sheet for appropriate steel Restraining collar material

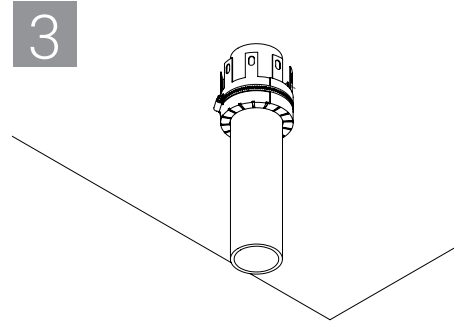

3  
Hold collar material in place using steel hose clamp. Hose Clamp positioned at mid height of each wrap strip stack

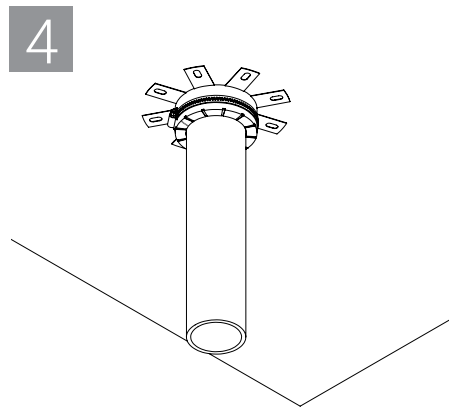

4  
Fold Retaining tabs toward penetrant and mounting tabs away from penetrant.

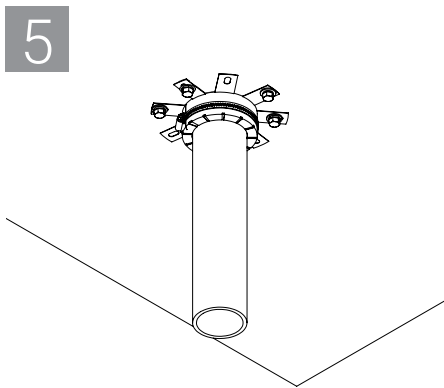

5  
Slide collar to tightly abut assembly surface. Mechanically fasten collar mounting tabs to assembly surface. Number of tabs and fastener requirements per appropriate UL System

TABLE B: WRAP STRIP GRADES

Catalog Number	Color	Max. Plastic Pipe Size
SSW125	Grey	2" (51 mm)
SSW250	Grey	3" (76 mm)
SSW375	Grey	4" (102 mm)
SSW375-12	Grey	6" (152 mm)
SSW1569	Grey	6" (152 mm)
SSW2538	Grey	12" (305 mm)
SSWBLU	Blue	14" (356 mm)
SSWBLU2	Blue	14" (356 mm)
SSWBLU220	Blue	2" (51 mm)
SSWBLU230	Blue	3" (76 mm)
SSWBLU240	Blue	4" (102 mm)
SSWRED	Red	6" (152 mm)
SSWRED2	Red	6" (152 mm)

Note: For more information on firestop installation, refer to ASTM E3157.

