



Airless Spray Technology

Owner's Manual

For professional use only

Do not use this equipment before reading this manual!

740ix

Airless Sprayer



Model Number:

High Rider Bare	800-1000
High Rider Complete	800-1005
Low Rider Bare	800-1010
Low Rider Complete	800-1015

NOTE: This manual contains important warnings and instructions. Please read and retain for reference.

Table of Contents

Safety Precautions	2
Français	14
Español	16
General Description	4
Operation	4
Setup	4
Preparing to Paint.....	4
Painting	5
Electronic Pressure Control Indicators	5
Pressure Relief Procedure	5
Spraying	6
Spraying Technique	6
Practice	6
Cleanup	7
Maintenance	7
General Repair and Service Notes.....	7
Replacing the Filters.....	8
Replacing the Motor (with Electronic Control).....	8
Replacing the Gears.....	9
Replacing the Transducer.....	9
Replacing the PRIME/SPRAY Valve.....	10
Servicing the Fluid Section	10
Troubleshooting	12
Parts Listings	18
Main Assembly.....	18
Motor Assembly	19
Electrical Schematic	19
Gear Box Assembly	20
High Rider Cart Assembly	21
Low Rider Cart Assembly	21
Fluid Section Assembly	22
Suction Set Assembly, Low Rider.....	23
Accessories	24
Labels	24
Warranty	24

Safety Precautions

This manual contains information that must be read and understood before using the equipment. When you come to an area that has one of the following symbols, pay particular attention and make certain to heed the safeguard.



This symbol indicates a potential hazard that may cause serious injury or loss of life. Important safety information will follow.



This symbol indicates a potential hazard to you or to the equipment. Important information that tells how to prevent damage to the equipment or how to avoid causes of minor injuries will follow.

NOTE: Notes give important information which should be given special attention.



HAZARD: Injection injury - A high pressure fluid stream produced by this equipment can pierce the skin and underlying tissues, leading to serious injury and possible amputation. See a physician immediately.

DO NOT TREAT AN INJECTION INJURY AS A SIMPLE CUT! Injection can lead to amputation. See a physician immediately.

The maximum operating range of the sprayer is 3300 PSI/228BAR fluid pressure.

PREVENTION:

- NEVER aim the gun at any part of the body.

- NEVER allow any part of the body to touch the fluid stream. DO NOT allow body to touch a leak in the fluid hose.
- NEVER put hand in front of the gun. Gloves will not provide protection against an injection injury.
- ALWAYS lock gun trigger, shut pump off, and release all pressure before servicing, cleaning tip or guard, changing tip, or leaving unattended. Pressure will not be released by turning off the motor. The PRIME/SPRAY valve handle must be turned to PRIME to relieve the pressure. Refer to the PRESSURE RELIEF PRESSURE described in the pump manual.
- ALWAYS keep tip guard in place while spraying. The tip guard provides some protection but is mainly a warning device.
- ALWAYS remove the spray tip before flushing or cleaning the system.
- Paint hose can develop leaks from wear, kinking and abuse. A leak can inject material into the skin. Inspect the hose before each use.
- NEVER use a spray gun without a working trigger lock and trigger guard in place.
- All accessories must be rated at or above 3300 PSI/228 BAR. This includes spray tips, guns, extensions, and hose.

NOTE TO PHYSICIAN:

Injection into the skin is a traumatic injury. It is important to treat the injury as soon as possible. DO NOT delay treatment to research toxicity. Toxicity is a concern with some coatings injected directly into the blood stream. Consultation with a plastic surgeon or reconstructive hand surgeon may be advisable.

HAZARD: EXPLOSION AND FIRE - Solvent and paint fumes can explode or ignite. Severe injury and/or property damage can occur.

PREVENTION:

- Provide extensive exhaust and fresh air introduction to keep the air within the spray area free from accumulation of flammable vapors.
- Avoid all ignition sources such as static electricity sparks, electrical appliances, flames, pilot lights, hot objects, and sparks from connecting and disconnecting power cords or working light switches.
- Do not smoke in spray area.
- Fire extinguisher must be present and in good working order.
- Place pump at least 20 feet (6.1 m) from the spray object in a well ventilated area (add more hose if necessary). Flammable vapors are often heavier than air. Floor area must be extremely well ventilated. The pump contains arcing parts that emit sparks and can ignite vapors.
- The equipment and objects in and around the spray area must be properly grounded to prevent static sparks.
- Use only conductive or grounded high-pressure fluid hose. Gun must be grounded through hose connections.
- Power cord must be connected to a grounded circuit.
- Always flush unit into separate metal container, at low pump pressure, with spray tip removed. Hold gun firmly against side of container to ground container and prevent static sparks.
- Follow material and solvent manufacturer's warnings and instructions.
- Use extreme caution when using materials with a flashpoint below 70° F (21° C). Flashpoint is the temperature at which a fluid can produce enough vapors to ignite.
- Plastic can cause static sparks. Never hang plastic to enclose spray area. Do not use plastic drop cloths when spraying flammable materials.
- Use lowest possible pressure to flush equipment.

GAS ENGINE (WHERE APPLICABLE)

Always place sprayer outside of structure in fresh air. Keep all solvents away from engine exhaust. Never fill fuel tank with a running or hot engine. Hot surface can ignite spilled fuel. Always attach ground wire from pump to a grounded object. Refer to engine owner's manual for complete safety information.

HAZARD: EXPLOSION HAZARD DUE TO INCOMPATIBLE MATERIALS - will cause severe injury or property damage.

PREVENTION:

- Do not use materials containing bleach or chlorine.
- Do not use halogenated hydrocarbon solvents such as bleach, mildewcide, methylene chloride and 1,1,1 - trichloroethane. They are not compatible with aluminum.
- Contact your coating supplier about the compatibility of material with aluminum.

HAZARD: HAZARDOUS VAPORS - Paints, solvents, insecticides, and other materials can be harmful if inhaled or come in contact with body. Vapors can cause severe nausea, fainting, or poisoning.

PREVENTION:

- Use a respirator or mask if vapors can be inhaled. Read all instructions supplied with the mask to be sure it will provide the necessary protection.
- Wear protective eyewear.
- Wear protective clothing as required by coating manufacturer.

HAZARD: GENERAL - Can cause severe injury or property damage.

PREVENTION:

- Read all instructions and safety precautions before operating equipment.
- Follow all appropriate local, state, and national codes governing ventilation, fire prevention, and operation.
- The United States Government Safety Standards have been adopted under the Occupational Safety and Health Act (OSHA). These standards, particularly part 1910 of the General Standards and part 1926 of the Construction Standards, should be consulted.
- Use only manufacturer authorized parts. User assumes all risks and liabilities when using parts that do not meet the minimum specifications and safety devices of the pump manufacturer.
- Before each use, check all hoses for cuts, leaks, abrasion or bulging of cover. Check for damage or movement of couplings. Immediately replace hose if any of those conditions exist. Never repair a paint hose. Replace with a grounded high-pressure hose.
- All hoses, swivels, guns, and accessories must be pressure rated at or above 3300PSI/228 BAR.
- Do not spray outdoors on windy days.
- Wear clothing to keep paint off skin and hair.
- Always unplug cord from outlet before working on equipment.

Grounding Instructions

This product must be grounded. In the event of an electrical short circuit, grounding reduces the risk of electric shock by providing an escape wire for the electric current. This product is equipped with a cord having a grounding wire with an appropriate grounding plug. The plug must be plugged into an outlet that is properly installed and grounded in accordance with all local codes and ordinances.

DANGER — Improper installation of the grounding plug can result in a risk of electric shock. If repair or replacement of the cord or plug is necessary, do not connect the green grounding wire to either flat blade terminal. The wire with insulation having a green outer surface with or without yellow stripes is the grounding wire and must be connected to the grounding pin.

Check with a qualified electrician or serviceman if the grounding instructions are not completely understood, or if you are in doubt as to whether the product is properly grounded. Do not modify the plug provided. If the plug will not fit the outlet, have the proper outlet installed by a qualified electrician.

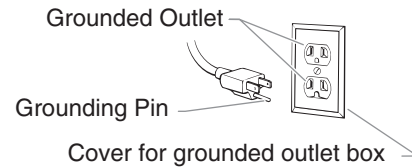

Use only a 3-wire extension cord that has a 3-blade grounding plug and a 3-slot receptacle that will accept the plug on the product. Make sure your extension cord is in good condition. When using an extension cord, be sure to use one heavy enough to carry the current your product will draw. An undersized cord will cause a drop in line voltage resulting in loss of power and overheating. A 12 gauge cord is recommended. If an extension cord is to be used outdoors, it must be marked with the suffix W-A after the cord type designation. For example, a designation of SJTW-A would indicate that the cord would be appropriate for outdoor use.

General Description

This airless sprayer is a precision power tool used for spraying many types of materials. Read and follow this instruction manual carefully for proper operating instructions, maintenance, and safety information.

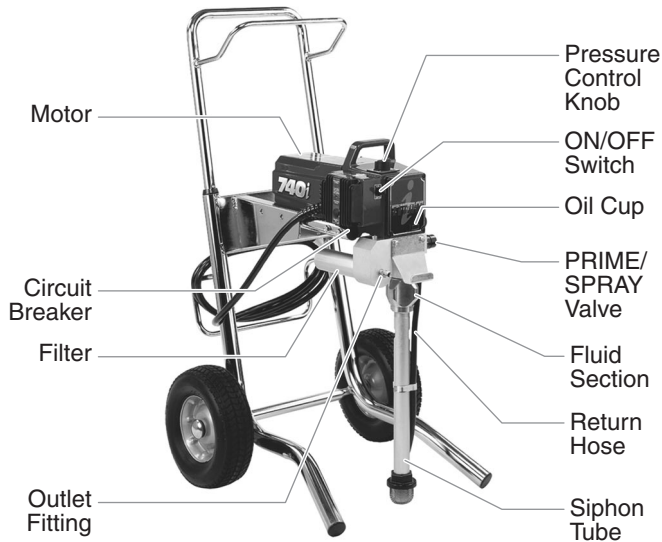

Operation

⚠ WARNING

This equipment produces a fluid stream at extremely high pressure. Read and understand the warnings in the Safety Precautions section at the front of this manual before operating this equipment.

Setup

Perform the following procedure before plugging in the power cord of an electric unit.

1. Ensure that the siphon tube/suction set and the return hose are attached and secure.
2. Using a wrench, attach a minimum of 50' of 1/4" nylon airless spray hose to the unit. Tighten securely.
3. Attach an airless spray gun to the spray hose. Using two wrenches (one on the gun and one on the hose), tighten securely.

NOTE: Do not attach the tip to the spray gun yet. Remove the tip if it is already attached.

⚠ WARNING

Make sure all airless hoses and spray guns are electrically grounded and rated for at least 3300 psi (228 bar) fluid pressure.

4. Make sure the pressure control knob is in its OFF position in the black zone.
5. Make sure the ON/OFF switch is in its OFF position.
6. Fill the oil cup with one tablespoon of piston seal lubricant (Piston Lube).

⚠ CAUTION

Never operate unit for more than ten seconds without fluid. Operating this unit without fluid will cause unnecessary wear to the packings.

7. Make sure the electrical service is 120V, 15 amp minimum.
8. Plug the power cord into a properly grounded outlet at least 25' from the spray area.

⚠ CAUTION

Always use a minimum 12 gauge, three-wire extension cord with a grounded plug. Never remove the third prong or use an adapter.

Preparing a New Sprayer

If this unit is new, it is shipped with test fluid in the fluid section to prevent corrosion during shipment and storage. This fluid must be thoroughly cleaned out of the system with mineral spirits before you begin spraying.

⚠ CAUTION

Always keep the trigger lock on the spray gun in the locked position while preparing the system.

1. Place the siphon tube into a container of mineral spirits.
2. Place the return hose into a metal waste container.
3. Set the pressure to minimum by turning the pressure control knob to the "Min" setting in the yellow zone.

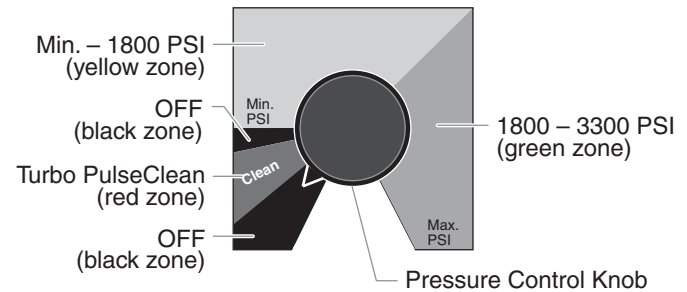

4. Move the PRIME/SPRAY valve down to the PRIME position.
5. Turn the unit on by moving the ON/OFF switch to the ON position.
6. Allow the sprayer to run for 15–30 seconds to flush the test fluid out through the return hose and into the waste container.
7. Turn the unit off by moving the ON/OFF switch to the OFF position.

Preparing to Paint

Before painting, it is important to make sure that the fluid in the system is compatible with the paint that is going to be used.

NOTE: Incompatible fluids and paint may cause the valves to become stuck closed, which would require disassembly and cleaning of the sprayer's fluid section.

⚠ CAUTION

Always keep the trigger lock on the spray gun in the locked position while preparing the system.

1. Place the siphon tube into a container of the appropriate solvent. Examples of the appropriate solvent are water for latex paint or mineral spirits for oil-based paints.
2. Place the return hose into a metal waste container.
3. Set the pressure to minimum by turning the pressure control knob to the "Min" setting in the yellow zone.
4. Move the PRIME/SPRAY valve down to the PRIME position.
5. Turn the unit on by moving the ON/OFF switch to the ON position.
6. Allow the sprayer to run for 15–30 seconds to flush the old solvent out through the return hose and into the metal waste container.
7. Turn the unit off by moving the ON/OFF switch to the OFF position.

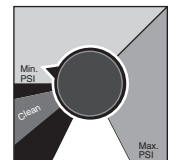

NOTE: Make sure that the spray gun does not have a tip or tip guard installed.

- Move the PRIME/SPRAY valve up to the SPRAY position.
- Turn the unit on.
- Unlock the gun by turning the gun trigger lock to the unlocked position.

⚠ WARNING

Ground the gun by holding it against the edge of the metal container while flushing. Failure to do so may lead to a static electric discharge, which may cause a fire.

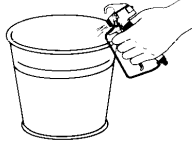

- Trigger the gun into the metal waste container until the old solvent is gone and fresh solvent is coming out of the gun.
- Lock the gun by turning the gun trigger lock to the locked position.
- Set down the gun and increase the pressure by turning the pressure control knob slowly clockwise into the green zone.
- Check the entire system for leaks. If leaks occur, follow the "Pressure Relief Procedure" in this manual before tightening any fittings or hoses.
- Follow the "Pressure Relief Procedure" in this manual before changing from solvent to paint.

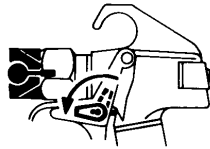

Trigger lock in locked position.

⚠ WARNING

Be sure to follow the pressure relief procedure when shutting the unit down for any purpose, including servicing or adjusting any part of the spray system, changing or cleaning spray tips, or preparing for cleanup.

Painting

- Place the siphon tube into a container of paint.
- Place the return hose into a metal waste container.
- Set the pressure to minimum by turning the pressure control knob to the "Min" setting in the yellow zone.
- Move the PRIME/SPRAY valve down to the PRIME position.
- Turn the unit on by moving the ON/OFF switch to the ON position.
- Allow the sprayer to run until paint is coming through the return hose into the metal waste container.
- Turn the unit off by moving the ON/OFF switch to the OFF position.
- Remove the return hose from the waste container and place it in its operating position above the container of paint.
- Move the PRIME/SPRAY valve up to the SPRAY position.
- Turn the unit on.
- Unlock the gun by turning the gun trigger lock to the unlocked position.

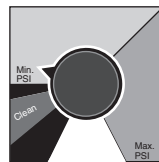

⚠ WARNING

Ground the gun by holding it against the edge of the metal container while flushing. Failure to do so may lead to a static electric discharge, which may cause a fire.

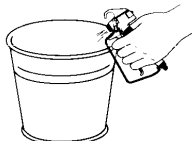

- Trigger the gun into the metal waste container until all air and solvent is flushed from the spray hose and paint is flowing freely from the gun.

- Lock the gun by turning the gun trigger lock to the locked position.
- Turn the unit off.
- Attach tip guard and tip to the gun as instructed by the tip guard or tip manuals.

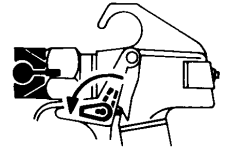

Trigger lock in locked position.

⚠ WARNING

POSSIBLE INJECTION HAZARD. Do not spray without the tip guard in place. Never trigger the gun unless the tip is in either the spray or the unclog position. Always engage the gun trigger lock before removing, replacing or cleaning tip.

- Turn the unit on.
- Increase the pressure by turning the pressure control knob slowly clockwise toward the green zone and test the spray pattern on a piece of cardboard. Adjust the pressure control knob until the spray from the gun is completely atomized. Try to keep the pressure control knob at the lowest setting that maintains good atomization.

NOTE: Turning the pressure up higher than needed to atomize the paint will cause premature tip wear and additional overspray.

Electronic Pressure Control Indicators

The following is a description of the indicators on the electronic pressure control.

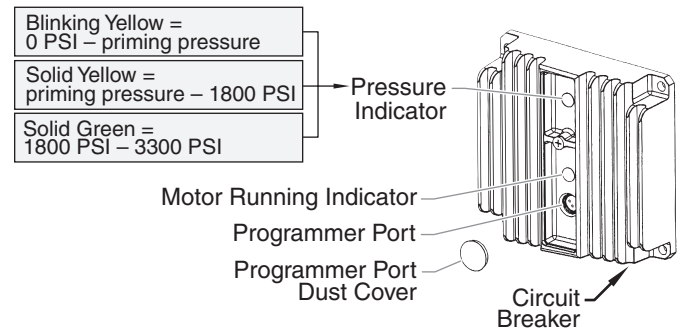

Pressure Relief Procedure

⚠ WARNING

Be sure to follow the pressure relief procedure when shutting the unit down for any purpose, including servicing or adjusting any part of the spray system, changing or cleaning spray tips, or preparing for cleanup.

- Lock the gun by turning the gun trigger lock to the locked position.
- Turn the unit off by moving the ON/OFF switch to the OFF position.
- Turn the pressure control knob counterclockwise to its OFF position in the black zone.
- Unlock the gun by turning the gun trigger lock to the unlocked position.
- Hold the metal part of the gun firmly to the side of a metal container to ground the gun and avoid a build up of static electricity.
- Trigger the gun to remove any pressure that may still be in the hose.
- Lock the gun by turning the gun trigger lock to the locked position.
- Move the PRIME/SPRAY valve down to the PRIME position.

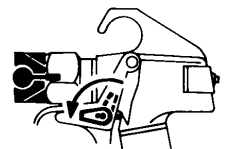

Trigger lock in locked position.



Spraying

⚠ WARNING

POSSIBLE INJECTION HAZARD. Do not spray without the tip guard in place. Never trigger the gun unless the tip is in either the spray or the unclog position. Always engage the gun trigger lock before removing, replacing, or cleaning tip.

Spraying Technique

The following techniques, if followed, will assure professional painting results.

Hold the gun perpendicular to the surface and always at equal distance from the surface. Depending on the type of material, surface, or desired spray pattern, the gun should be held at a distance of 12 to 14 inches (30 to 35 cm).

Move the gun either across or up and down the surface at a steady rate. Moving the gun at a consistent speed conserves material and provides even coverage. The correct spraying speed allows a full, wet coat of paint to be applied without runs or sags.

Holding the gun closer to the surface deposits more paint on the surface and produces a narrower spray pattern. Holding the gun farther from the surface produces a thinner coat and wider spray pattern. If runs, sags, or excessive paint occur, change to a spray tip with a smaller orifice. If there is an insufficient amount of paint on the surface or you desire to spray faster, a larger orifice tip should be selected.

Maintain uniform spray stroke action. Spray alternately from left to right and right to left. Begin movement of the gun before the trigger is pulled.

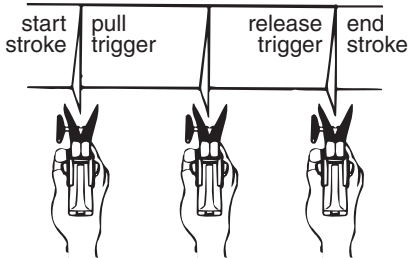

Avoid arcing or holding the gun at an angle. This will result in an uneven finish.

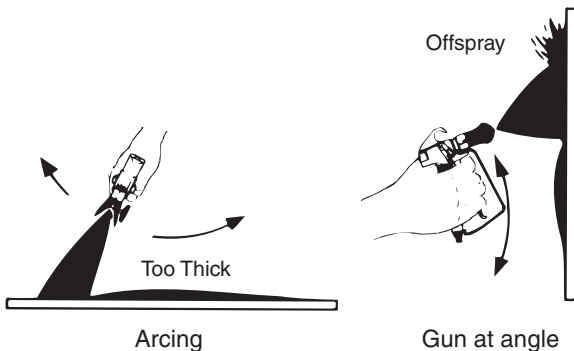

Proper lapping (overlap of spray pattern) is essential to an even finish. Lap each stroke. If you are spraying horizontally, aim at the bottom edge of the preceding stroke, so as to lap the previous pattern by 50%.

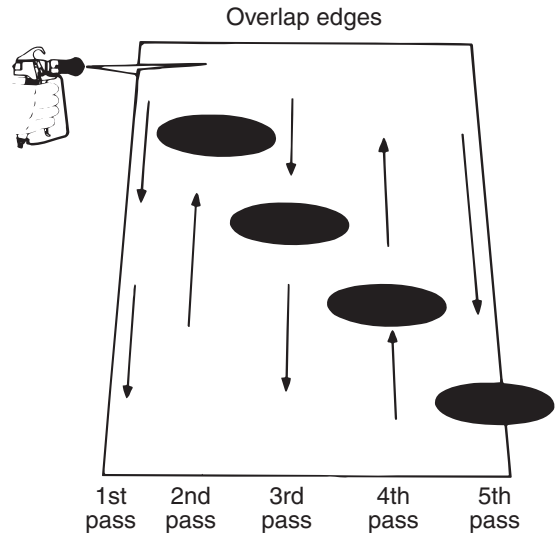

For corners and edges, split the center of the spray pattern on the corner or edge and spray vertically so that both adjoining sections receive approximately even amounts of paint.

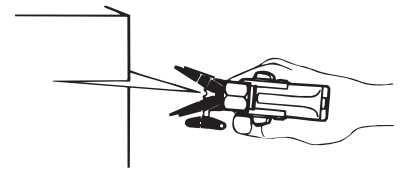

When spraying with a shield, hold it firmly against the surface. Angle the spray gun slightly away from the shield and toward the surface. This will prevent paint from being forced underneath.

Shrubs next to houses should be tied back and covered with a canvas cloth. The cloth should be removed as soon as possible. Titan gun extensions are extremely helpful in these situations.

Nearby objects such as automobiles, outdoor furniture, etc. should be moved or covered whenever in the vicinity of a spray job. Be careful of any other surrounding objects that could be damaged by overspray.

Practice

1. Be sure that the paint hose is free of kinks and clear of objects with sharp cutting edges.
2. Turn the pressure control knob counterclockwise to its lowest setting.
3. Turn the PRIME/SPRAY valve up to its SPRAY position.
4. Turn the pressure control knob clockwise to its highest setting. The paint hose should stiffen as paint begins to flow through it.
5. Unlock the gun trigger lock.
6. Trigger the spray gun to bleed air out of the hose.
7. When paint reaches the spray tip, spray a test area to check the spray pattern.
8. Use the lowest pressure setting necessary to get a good spray pattern. If the pressure is set too high, the spray pattern will be too light. If the pressure is set too low, tailing will appear or the paint will spatter out in gobs rather than in a fine spray.

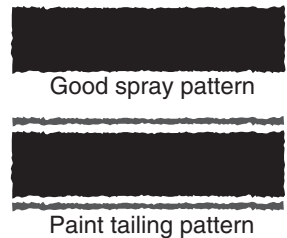

Cleanup

⚠ WARNING

Special cleanup instructions for use with flammable solvents:

- Always flush spray gun preferably outside and at least one hose length from spray pump.
- If collecting flushed solvents in a one gallon metal container, place it into an empty five gallon container, then flush solvents.
- Area must be free of flammable vapors.
- Follow all cleanup instructions.

⚠ CAUTION

The sprayer, hose, and gun should be cleaned thoroughly after daily use. Failure to do so permits material to build up, seriously affecting the performance of the unit.

⚠ WARNING

Always spray at minimum pressure with the gun nozzle tip removed when using mineral spirits or any other solvent to clean the sprayer, hose, or gun. Static electricity buildup may result in a fire or explosion in the presence of flammable vapors.

1. Follow the "Pressure Relief Procedure" found in the Operation section of this manual.
2. Remove the gun tip and tip guard and clean with a brush using the appropriate solvent.
3. Place the siphon tube into a container of the appropriate solvent. Examples of the appropriate solvent are water for latex paint or mineral spirits for oil-based paints.
4. Place the return hose into a metal waste container.
5. Move the PRIME/SPRAY valve down to its PRIME position.
6. Set the pressure to Turbo PulseClean by turning the pressure control knob to its CLEAN position in the red zone.
7. Turn the unit on by moving the ON/OFF switch to the ON position.
8. Allow the solvent to circulate through the unit and flush the paint out of the return hose into the metal waste container.
9. Turn the unit off by moving the ON/OFF switch to the OFF position.
10. Move the PRIME/SPRAY valve up to its SPRAY position.
11. Turn the unit on.

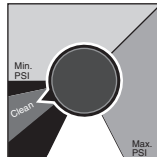

⚠ WARNING

Ground the gun by holding it against the edge of the metal container while flushing. Failure to do so may lead to a static electric discharge, which may cause a fire.



12. Trigger the gun into the metal waste container until the paint is flushed out of the hose and solvent is coming out of the gun.
13. Continue to trigger the spray gun into the waste container until the solvent coming out of the gun is clean.

NOTE: For long-term or cold weather storage, pump mineral spirits through the entire system.
For short-term storage when using latex paint, pump water mixed with Titan Liquid Shield through the entire system (see the Accessories section of this manual for part number).

14. Follow the "Pressure Relief Procedure" found in the Operation section of this manual.
15. Unplug the unit and store in a clean, dry area.

⚠ CAUTION

Do not store the unit under pressure.

Maintenance

⚠ WARNING

Before proceeding, follow the Pressure Relief Procedure outlined previously in this manual. Additionally, follow all other warnings to reduce the risk of an injection injury, injury from moving parts or electric shock. Always unplug the sprayer before servicing!

General Repair and Service Notes

The following tools are needed when repairing this sprayer:

Phillips Screwdriver	3/8" Hex Wrench
Needle Nose Pliers	5/16" Hex Wrench
Adjustable Wrench	1/4" Hex Wrench
Rubber Mallet	3/16" Hex Wrench
Flat-blade Screwdriver	5/32" Hex Wrench

1. Before repairing any part of the sprayer, read the instructions carefully, including all warnings.

⚠ CAUTION

Never pull on a wire to disconnect it. Pulling on a wire could loosen the connector from the wire.

2. Test your repair before regular operation of the sprayer to be sure that the problem is corrected. If the sprayer does not operate properly, review the repair procedure to determine if everything was done correctly. Refer to the Troubleshooting Charts to help identify other possible problems.
3. Make certain that the service area is well ventilated in case solvents are used during cleaning. Always wear protective eyewear while servicing. Additional protective equipment may be required depending on the type of cleaning solvent. Always contact the supplier of solvents for recommendations.
4. If you have any further questions concerning your TITAN Airless Sprayer, call TITAN:

Customer Service (U.S.)	1-800-526-5362
Fax	1-800-528-4826
Customer Service (Canada)	1-800-565-8665
Fax	1-905-856-8496
Customer Service (International)	1-201-405-7520
Fax	1-201-405-7449

Replacing the Filters

Pump Filter

1. Loosen and remove the filter housing by hand.
2. Slip the filter off of the filter support spring.
3. Inspect the filter. Based on inspection, clean or replace the filter.
4. Inspect the o-ring. Based on inspection, clean or replace the o-ring.
5. Slide the new or cleaned filter over the filter support spring with the adapter in place. Push the filter into the center of the pump block.
6. Slide the filter housing over the filter and thread it into the pump block until secure.

NOTE: The filter housing should be hand-tightened, but make sure the filter housing is seated fully into the pump block.

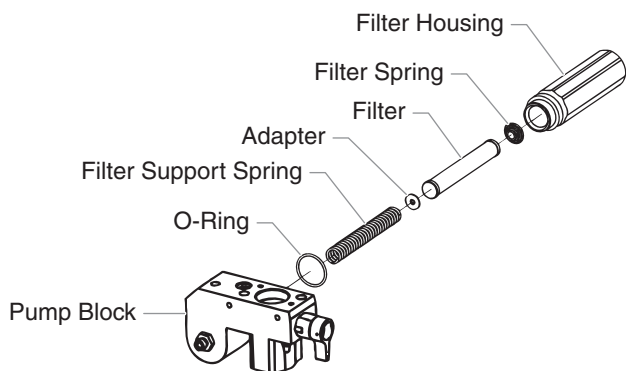

Gun Filter

1. Move the gun trigger lock to the unlocked position.
2. Loosen and remove the handle from the gun body.
3. Turning clockwise, unscrew the filter from the gun body.

NOTE: Left-handed threads require turning the filter clockwise to remove.

4. Turning counterclockwise, screw the new or cleaned filter into the gun body.
5. Make sure the handle seal is in position and thread the handle into the gun body until secure.
6. Move the gun trigger lock to the locked position.

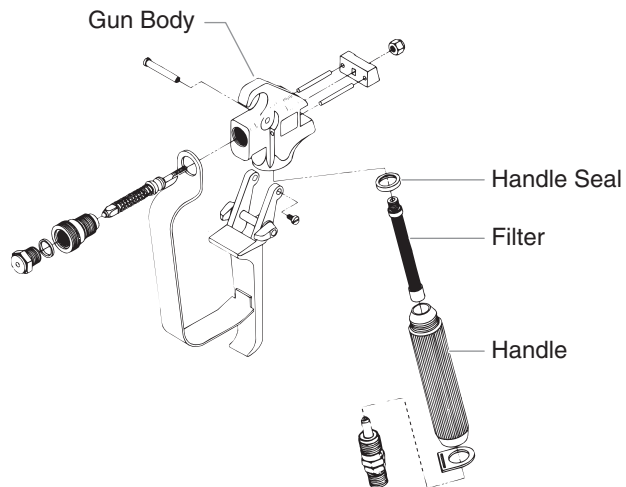

NOTE: For more detail, part number information, and assembly drawings at larger scale, please see the LX -80 Professional Airless Gun Owner's Manual (#313-012).

Replacing the Motor (with Electronic Control)

⚠ WARNING

Electrostatic discharge (ESD) potential could cause damage to electronic control. Use Titan ESD wrist strap P/N 700-1037 or equivalent when working on electronic control with electronic cover removed.

1. Unplug the unit.
2. Loosen and remove the four motor shroud screws. Remove the motor shroud.
3. Release the baffle tape on the side of the baffle assembly and slip the baffle assembly off of the motor. Remove the four baffle spacers.
4. Slide the electronic cover off of the electronic control assembly on the motor.
5. Loosen and remove the four heat sink assembly mounting screws. Pull back the heat sink assembly to access and disconnect the two wires coming from the motor.
6. At the electronic control assembly:
 - a. Disconnect the white wire coming from the power cord and the white wire coming from the ON/OFF switch.
 - b. Disconnect the three wires coming from the potentiometer and the phone jack-style connector coming from the transducer.
 - c. Disconnect the seven wires coming from the indicator lights assembly.
7. Loosen and remove the four motor mounting screws.
8. Pull the motor out of the gear box housing.
9. With the motor removed, inspect the gears in the gear box housing for damage or excessive wear. Replace the gears, if necessary.

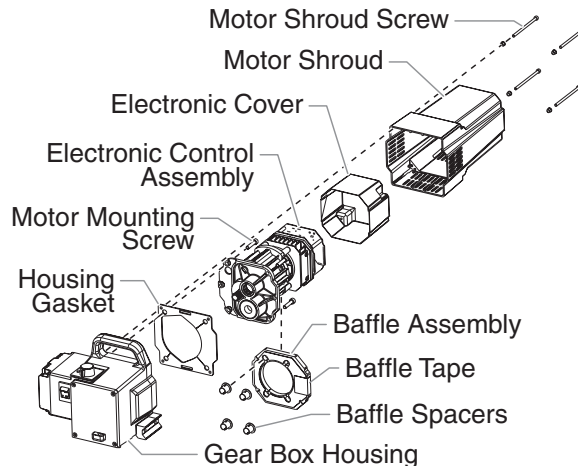

10. Install the new motor into the gear box housing. Make sure the housing gasket is positioned properly.
11. Secure the motor with the four motor mounting screws.
12. Reconnect the wires to the electronic control assembly (refer to the electrical schematic in the Parts List section of this manual).
13. Connect the two motor wires to the heat sink assembly.
14. Position the electronic cover over the electronic control assembly.
15. Position the heat sink assembly on the gear box housing and secure in position with the four heat sink assembly mounting screws.
16. Slip the baffle assembly with the baffle tape. Slip the four baffle spacers into position between the rear bell of the motor and the baffle assembly.
17. Slide the motor shroud over the motor. Make sure the housing gasket is positioned properly.
18. Secure the motor shroud with the four motor shroud screws.

Replacing the Gears

1. Unplug the unit.
2. Loosen and remove the four motor shroud screws. Remove the motor shroud.
3. Release the baffle tape on the side of the baffle assembly and slip the baffle assembly off of the motor. Remove the four baffle spacers.
4. Slide the electronic cover off of the electronic control assembly on the motor.
5. Loosen and remove the four heat sink assembly mounting screws. Pull back the heat sink assembly to access and disconnect the two wires coming from the motor.
6. At the electronic control assembly:
 - a. Disconnect the white wire coming from the power cord and the white wire coming from the ON/OFF switch.
 - b. Disconnect the three wires coming from the potentiometer and the phone jack-style connector coming from the transducer.
 - c. Disconnect the seven wires coming from the indicator lights assembly.
7. Loosen and remove the four motor mounting screws.
8. Pull the motor out of the gear box housing.
9. Inspect the rotor gear on the end of the motor for damage or excessive wear. If this gear is completely worn out, replace the motor.
10. Remove and inspect the 2nd stage gear assembly for damage or excessive wear. Replace, if necessary.
11. Remove and inspect the crankshaft/gear assembly for damage or excessive wear. If damaged or worn, replace the crankshaft/gear assembly.

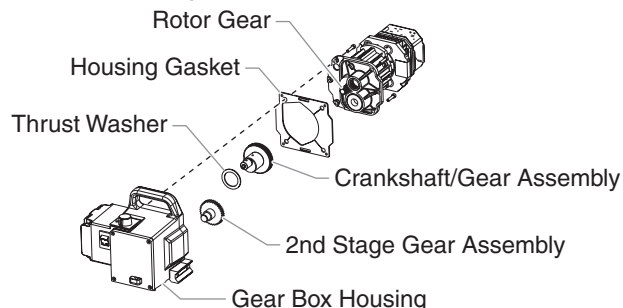

NOTE: Clean and refill the gear box cavity up to the rear face of each gear with Lubriplate (P/N 314-171).

12. Install the motor into the gear box housing. Make sure the housing gasket is positioned properly and the thrust washer is in place.
13. Secure the motor with the four motor mounting screws.
14. Reconnect the wires to the electronic control assembly (refer to the electrical schematic in the Parts List section of this manual).
15. Connect the two motor wires to the heat sink assembly.
16. Position the electronic cover over the electronic control assembly.
17. Position the heat sink assembly on the gear box housing and secure in position with the four heat sink assembly mounting screws.
18. Slip the baffle assembly around the motor. Secure the baffle assembly with the baffle tape. Slip the four baffle spacers into position between the rear bell of the motor and the baffle assembly.
19. Slide the motor shroud over the motor. Make sure the housing gasket is positioned properly.
20. Secure the motor shroud with the four motor shroud screws.

Replacing the Transducer

1. Loosen and remove the four front cover screws. Remove the front cover.
2. Stop the sprayer at the bottom of its stroke so that the piston is in its lowest position. Turn off and unplug the sprayer.

WARNING

Before proceeding, follow the Pressure Relief Procedure outlined previously in this manual. Additionally, follow all other warnings to reduce the risk of an injection injury, injury from moving parts or electric shock. Always unplug the sprayer before servicing!

3. Tilt the pump back for easy access to the fluid section.
4. Using a 3/8" hex wrench, loosen and remove the two pump block mounting screws.
5. Pull the pump block down approximately 1/2" from the gear box housing to clear the transducer.
6. Slide the pump block and piston rod forward until the piston rod is out of the T-slot on the slider assembly.
7. Loosen and remove the four heat sink assembly mounting screws.
8. Pull back the heat sink assembly for access to the transducer wire plug-in.
9. Follow the wire from the transducer to the heat sink assembly and unplug the transducer wire from the heat sink assembly.
10. Using an 1/8" hex wrench, loosen and remove the set screw from the bottom of the gear box housing.
11. Slide the transducer assembly out of the bottom of the gear box housing.
12. Install the new transducer assembly into the gear box housing.
13. Thread the set screw into the gear box housing and tighten securely.
14. Plug the transducer wire into the heat sink assembly where the old transducer wire was located.
15. Reassemble the pump by reversing steps 1–8.

CAUTION

Make sure the transducer is aligned properly with the hole in the pump block during reassembly. Improper alignment may cause damage to the transducer gasket.

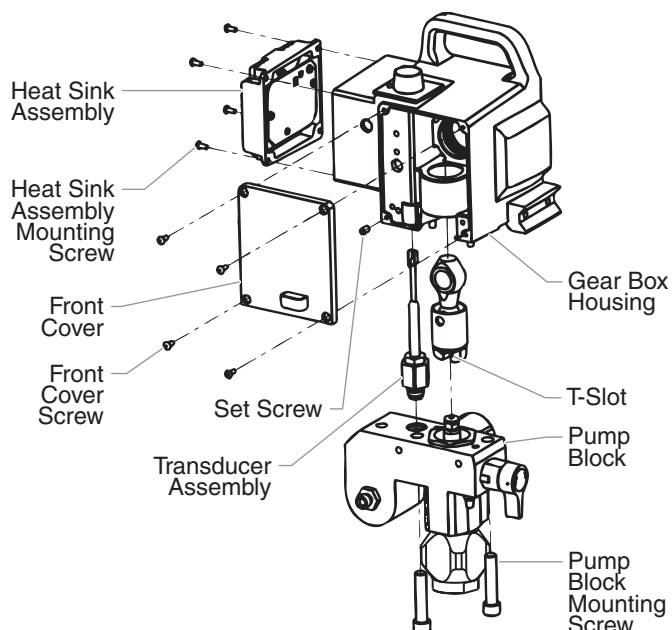

Replacing the PRIME/SPRAY Valve

Perform the following procedure using PRIME/SPRAY valve replacement kit P/N 800-915.

1. Push the groove pin out of the valve handle.
2. Remove the valve handle and the cam base.
3. Using a wrench, loosen and remove the valve housing assembly.
4. Make sure the gasket is in place and thread the new valve housing assembly into the pump block. Tighten securely with wrench.
5. Place the cam base over the valve housing assembly. Lubricate the cam base with grease and line up the cam with the pump block using the dowel pin.
6. Line up the hole on the valve stem with the hole in the valve handle.
7. Insert the groove pin into the valve handle and through the valve stem to secure the valve handle in position.

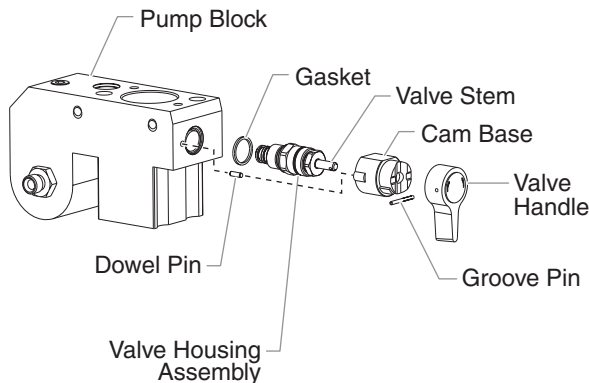

Servicing the Fluid Section

Use the following procedures to service the valves and repack the fluid section. Perform the following steps before performing any maintenance on the fluid section.

1. Loosen and remove the four front cover screws. Remove the front cover.
2. Stop the sprayer at the bottom of its stroke so that the piston is in its lowest position. Turn off and unplug the sprayer.



Before proceeding, follow the Pressure Relief Procedure outlined previously in this manual. Additionally, follow all other warnings to reduce the risk of an injection injury, injury from moving parts or electric shock. Always unplug the sprayer before servicing!

2. For High Rider units, remove the return hose from the clamp on the siphon tube. Unscrew the siphon tube from the foot valve housing.
3. For Low Rider units, remove the retaining clip from the bottom of the foot valve housing. Unscrew the return hose from the pump block and remove the suction set assembly.
5. Tilt the pump back for easy access to the fluid section.

Servicing the Valves

The design of Titan's fluid section allows access to the foot valve and seat as well as the outlet valve and seat without completely disassembling the fluid section. It is possible that the valves may not seat properly because of debris stuck in the foot valve seat or outlet valve seat. Use the following instructions to clean the valves and reverse or replace the seats.

1. Loosen and remove the foot valve housing from the pump block.
2. Remove the lower cage, foot valve ball, foot valve seat, and o-ring from the foot valve housing.
3. Clean out any debris in the foot valve housing and examine the valve housing and seat. If the seat is damaged, reverse or replace the seat.
4. Remove the adapter from the pump block.
5. Using a 3/8" hex wrench, loosen and remove the outlet valve retainer from the piston rod.

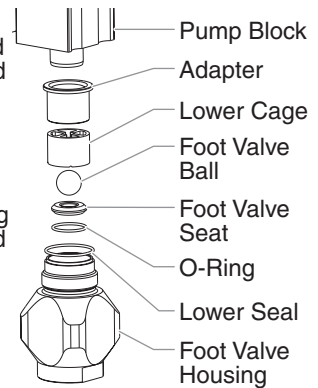

NOTE: Always service the outlet valve with the piston rod attached to the pump. This will prevent the piston rod from rotating during disassembly of the outlet valve.

6. Remove the upper seal, upper cage, nylon washer, outlet valve ball, and outlet valve seat from the outlet valve retainer.
7. Clean out any debris and examine the outlet valve retainer and outlet valve seat. If the seat is damaged, reverse or replace the seat.
8. Clean and inspect the upper cage and outlet valve ball. Replace if they are worn or damaged.
9. Reassemble the valves by reversing the steps above.

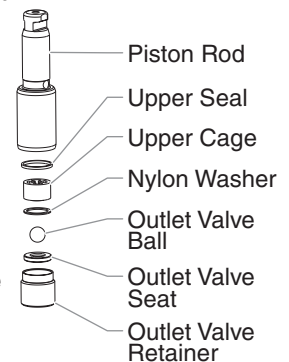

NOTE: During reassembly, make sure the o-ring between the pump block and foot valve housing is lubricated with grease and in position.

Repacking the Fluid Section

NOTE: The factory-installed packings are black in color. The replacement packings in the packing replacement kit are white.

1. Remove the foot valve assembly using the steps in the "Servicing the Valves" procedure above.

NOTE: The outlet valve does not need to be disassembled from the piston rod for this procedure.

2. Using 3/8" hex wrench, loosen and remove the two pump block mounting screws.
3. Pull the pump block down approximately 1/2" from the gear box housing.
4. Slide the pump block and piston rod forward until the piston rod is out of the T-slot on the slider assembly.
5. Slide the piston rod out through the bottom of the pump block.
6. Loosen and remove the retainer nut and piston guide from the pump block.
7. Remove the upper and lower packings from the pump block.
8. Clean the pump block.
9. Locate the new upper and lower packings and pack the areas between the packing lips with grease. Lubricate the o-rings on the exterior of the packings with grease.
10. Insert the upper packing into the top of the pump block with the raised lip on the packing facing down.
11. Insert the piston guide into the retainer nut. Thread the retainer nut into the pump block until it is hand tight.
12. Pre-form the lower packing using the lower packing sizing tool (included in the repacking kit).
13. Insert the lower packing partially into the bottom of the pump block so that the side that has the o-ring closest to the face of the packing faces up.
14. Push the lower packing into position using the lower packing insertion tool (see Fluid Section Assembly parts list for lower packing insertion tool P/N).
15. Inspect the piston rod for wear and replace if necessary.

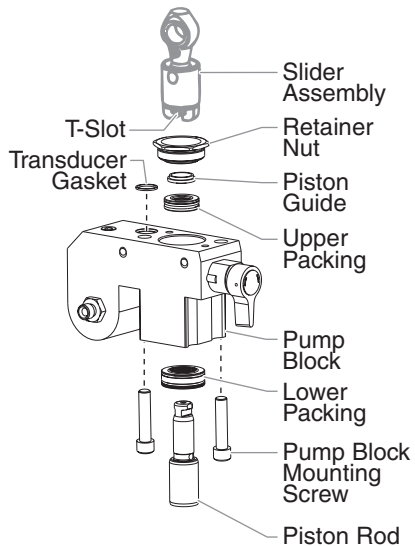

Install upper packing with raised lip and o-ring facing down.

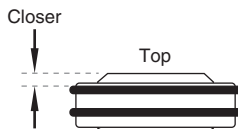

Install lower packing with the side that has the o-ring closest to the top of the packing facing up.

NOTE: Coat the piston insertion tool and the piston rod with grease before inserting them into the pump block.

16. Place the piston insertion tool (included in the repacking kit) over the top of the piston rod.

17. Insert the piston rod into the bottom of the pump block, through the lower packing, through the upper packing, and out through the retainer nut. Using a rubber mallet, tap the bottom of the piston rod lightly until the piston rod is in position in the pump block.

NOTE: When repacking the fluid section, make sure the raised lip on the bottom of the lower packing is fully outside the packing around the piston rod after insertion of the piston rod.

18. Remove the piston insertion tool from the top of the piston rod.
19. Using a wrench, tighten the retainer nut into the pump block. Torque to 25-30 ft. lbs.
20. Slide the top of the piston rod into the T-slot on the slider assembly.
21. Position the pump block underneath the gear box housing and push up until it rests against the gear box housing.

CAUTION

Make sure the transducer is aligned properly with the hole in the pump block during reassembly. Improper alignment may cause damage to the transducer gasket.

22. Thread the pump block mounting screws through the pump block and into the gear box housing. Tighten securely.
23. Reassemble the foot valve assembly into the pump block.

NOTE: During reassembly, make sure the o-ring between the pump block and foot valve housing is lubricated with grease and in position.

24. For High Rider units, thread the siphon tube into the foot valve housing and tighten securely. Make sure to wrap the threads on the siphon tube with PTFE tape before assembly. Replace the return hose into the clamp on the siphon tube.
25. For Low Rider units, insert the elbow on the suction set assembly into the bottom of the foot valve housing. Position the retaining clip up into the foot valve housing to secure the suction set assembly.
26. Thread the return hose into the pump block and tighten securely.
27. Place the front cover on the gear box housing and secure in position using the four front cover screws.
28. Turn on the sprayer by following the procedure in the "Operation" section of this manual and check for leaks.

NOTE: Repacking kit P/N 800-450 is available. For best results use all parts supplied in this kit.

Troubleshooting

Problem

The unit will not run.

Cause

1. The unit is not plugged in.
2. Tripped breaker.
3. The pressure is set too low (pressure control knob set at minimum setting does not supply power to unit).
4. Faulty or loose wiring.
5. Excessive motor temperature.
6. ON/OFF switch is defective.

Solution

1. Plug the unit in.
2. Reset the breaker.
3. Turn the pressure control knob clockwise to supply power to the unit and increase the pressure setting.
4. Inspect or take to a Titan authorized service center.
5. Allow motor to cool.
6. Replace the ON/OFF switch.

The unit will not prime.

1. The PRIME/SPRAY valve is in the SPRAY position.
2. Air leak in the siphon tube/suction set.
3. The pump filter and/or inlet screen is clogged.
4. The siphon tube/suction set is clogged.

1. Rotate the PRIME/SPRAY valve clockwise to the PRIME position.
2. Check the siphon tube/suction set connection and tighten or re-tape the connection with PTFE tape.
3. Remove the pump filter element and clean. Remove the inlet screen and clean.
4. Remove the siphon tube/suction set and clean.

The unit will not build or maintain pressure.

1. The spray tip is worn.
2. The spray tip is too large.
3. The pressure control knob is not set properly.
4. The pump filter, gun filter, or inlet screen is clogged.
5. Material flows from the return hose when the PRIME/SPRAY valve is in the SPRAY position.
6. Air leak in the siphon tube/suction set.
7. There is external fluid leak.
8. There is an internal fluid section leak (packings are worn and/or dirty, valve balls are worn).
9. Worn valve seats
10. Motor powers but fails to rotate

1. Replace the spray tip following the instructions that came with the spray gun.
2. Replace the spray tip with a tip that has a smaller orifice following the instructions that came with the spray gun.
3. Turn the pressure control knob clockwise to increase the pressure setting.
4. Remove the pump filter element and clean. Remove the gun filter and clean. Remove the inlet screen and clean.
5. Clean or replace the PRIME/SPRAY valve.
6. Check the siphon tube/suction set connection and tighten or re-tape the connection with PTFE tape.
7. Check for external leaks at all connections. Tighten connections, if necessary.
8. Clean the valves and service the fluid section following the "Servicing the Fluid Section" procedure in the Maintenance section of this manual.
9. Reverse or replace the valve seats following the "Servicing the Fluid Section" procedure in the Maintenance section of this manual.
10. Take unit to a Titan authorized service center.

Fluid leakage at the upper end of the fluid section.

1. The upper packings are worn.
2. The piston rod is worn.

1. Repack the pump following the "Servicing the Fluid Section" procedure in the Maintenance section of this manual.
2. Replace the piston rod following the "Servicing the Fluid Section" procedure in the Maintenance section of this manual.

Troubleshooting

Problem

Excessive surge at the spray gun.

Cause

1. Wrong type of airless spray hose.
2. The spray tip worn or too large.
3. Excessive pressure.

Solution

1. Replace hose with a minimum of 50' of 1/4" grounded textile braid airless paint spray hose.
2. Replace the spray tip following the instructions that came with the spray gun.
3. Rotate the pressure control knob counterclockwise to decrease spray pressure.

Poor spray pattern.

-
1. The spray tip is too large for the material being used.
 2. Incorrect pressure setting.
 3. Insufficient fluid delivery.
 4. The material being sprayed is too viscous.

-
1. Replace the spray tip with a new or smaller spray tip following the instructions that came with the spray gun.
 2. Rotate the pressure control knob to adjust the pressure for a proper spray pattern.
 3. Clean all screens and filters.
 4. Add solvent to the material according to the manufacturer's recommendations.

The unit lacks power.

-
1. The pressure adjustment is too low.
 2. Improper voltage supply.

-
1. Rotate the pressure control knob clockwise to increase the pressure setting.
 2. Reconnect the input voltage for 120V AC.

Patents

These products are covered by one or more of the following U.S. patents:

4,500,119 4,768,929

Consignes de sécurité

Le présent manuel comprend des renseignements devant être lus attentivement avant toute utilisation de l'appareil. Lorsque l'un des symboles suivants apparaît, il est recommandé d'être particulièrement attentif et de tenir compte des mesures de sécurité indiquées.

⚠ AVERTISSEMENT

Ce symbole indique un danger potentiel pouvant causer des blessures graves ou même mortelles. Des renseignements importants sur la sécurité sont également indiqués.

⚠ ATTENTION

Ce symbole indique un danger potentiel pouvant causer des blessures corporelles ou des dommages à l'équipement. Des renseignements importants sur la façon de prévenir tout dommage à l'équipement ou toute blessure corporelle mineure sont également indiqués.

NOTA : Les remarques donnent des renseignements importants requérant une attention particulière.

⚠ AVERTISSEMENT

DANGER: BLESSURES PAR PERFORATION - Le jet de peinture à haute pression produit par cet appareil peut perforer la peau et les tissus sous-jacents et entraîner de sévères blessures pouvant nécessiter une amputation. Consultez immédiatement un médecin.

NE PAS TRAITER UNE BLESSURE PAR PERFORATION COMME UNE SIMPLE COUPURE! Une perforation peut entraîner des risques d'amputation. Consultez immédiatement un médecin.

Pression de service maximale du fluide dans l'appareil : 3300 lb/po2 / 228BAR.

MESURES PRÉVENTIVES:

- NE JAMAIS diriger le pistolet vers une quelconque partie du corps.
- NE JAMAIS mettre une quelconque partie du corps en contact avec le jet de liquide. NE JAMAIS se mettre au contact d'un jet de liquide provenant d'une fuite du flexible d'alimentation en liquide.
- NE JAMAIS placer votre main devant le pistolet. Des gants ne vous protégeront pas contre les risques de blessures par perforation.
- TOUJOURS verrouiller la gâchette du pistolet, fermer la pompe à liquide et décompresser l'appareil lorsque vous travaillez sur celui-ci, nettoyez le protecteur de tête, remplacez la tête de pulvérisation ou vous éloignez de l'appareil. Couper le moteur ne décompresse pas l'appareil. Vous devez, pour le décompresser, placer le bouton AMORÇAGE/PULVÉRISATION en position AMORÇAGE. Reportez-vous, pour cela, à la PROCÉDURE DE DÉCOMPRESSION décrite dans de ce manuel.
- TOUJOURS s'assurer que le protecteur de tête est en place lorsque vous pulvériser. Le protecteur de tête offre une certaine protection contre les blessures par perforation mais sa principale fonction est d'ordre préventif.
- TOUJOURS ôter la tête de pulvérisation avant de purger ou nettoyer l'appareil.
- Le flexible d'alimentation en peinture peut fuir à la suite d'une usure, de chocs ou de mauvais traitements. Une fuite peut entraîner une perforation de la peau. Inspecter le flexible avant chaque utilisation.
- NE JAMAIS utiliser un pistolet dont la gâchette n'est pas munie d'un loquet ou un cran de sécurité qui soit en état de fonctionner.
- Tous les accessoires doivent être homologués pour une pression égale ou supérieure à 3300 lb/po2 / 228BAR. Cela s'applique, entre autres, aux têtes de pulvérisation, aux accessoires du pistolet et aux flexibles.

AVERTISSEMENT AUX MÉDECINS : Une perforation sous-cutanée constitue un traumatisme. Il est important de traiter la blessure de façon chirurgicale aussitôt que possible. NE RETARDEZ PAS ce traitement pour des recherches de toxicité. La toxicité n'est un risque que dans les cas où certains produits de revêtement pénètrent dans le flux sanguin. Il peut être nécessaire de faire appel à des soins de chirurgie plastique ou de reconstruction de la main.

DANGER: RISQUES D'EXPLOSION OU D'INCENDIE - Les vapeurs dégagées par le solvant ou la peinture sont explosives et inflammables et peuvent causer des corporels sérieux ou dommages matériels.

MESURES PRÉVENTIVES:

- Veiller à éviter toute accumulation de vapeurs inflammables en vous assurant que la zone où la pulvérisation a lieu est suffisamment ventilée.
- Veiller à éviter la présence de toute source incandescente telle qu'étincelle électrostatique, flamme nue, flamme-pilote, objet brûlant, cigarette et étincelle provenant du branchement ou du débranchement d'un cordon d'alimentation électrique ou d'un commutateur.
- Ne pas fumer dans la zone d'épandage.
- Toujours avoir un extincteur en état de fonctionner à portée de la main.
- Placer la pompe à peinture à une distance d'au moins un mètre (3 pi) (on recommande d'ailleurs une plus grande distance) de l'objet qui doit être vaporisé dans une pièce séparée bien aérée, ou à une distance d'au moins six mètres (20 pi) de celui-ci dans une zone bien aérée (utiliser d'autres tuyaux si nécessaires). Les vapeurs inflammables sont souvent plus lourdes que l'air. Le plancher doit être extrêmement bien aéré. La pompe à peinture contient des pièces pouvant créer des étincelles et enflammer les vapeurs présentes dans l'air.
- Le matériel utilisé, ainsi que les objets se trouvant à proximité de la zone de pulvérisation, doivent être convenablement reliés à la terre afin d'éviter toute étincelle ou toute décharge électrostatique.
- N'utiliser que des flexibles d'alimentation en liquide à haute pression conducteurs ou reliés à la terre dans les cas d'utilisation sans air comprimé. S'assurer que le pistolet est convenablement relié à la terre par l'intermédiaire du flexible.
- Le cordon d'alimentation doit être raccordé à un circuit mis à la terre.
- Toujours purger l'appareil dans un contenant métallique séparé, en s'assurant que la pompe soit à basse pression et que le chapeau soit retiré. Tenir le pistolet fermement contre la paroi du contenant pour mettre celui-ci à la terre et empêcher l'émission d'étincelles causées par l'électricité statique.
- Se conformer aux consignes et recommandations de sécurité du fabricant du solvant ou du produit.
- S'entourer de toutes les précautions possibles lorsqu'on utilise des produits ayant un point d'éclair inférieur à 21 °C (70 °F). Le point d'éclair d'un fluide est la température à laquelle les vapeurs émanant du fluide peuvent s'enflammer au contact d'une flamme ou d'une étincelle.
- Le plastique peut être une source d'étincelles provoquées par l'électricité statique. Ne jamais utiliser une couverture en plastique pour fermer une zone d'épandage ni utiliser des toiles de protection en plastique lors de la pulvérisation de matières inflammables.
- Lorsque vous purgez l'appareil, veillez à utiliser à la pression minimale.

MOTEUR À ESSENCE (DANS LES CAS OÙ CELA S'APPLIQUE)

Toujours placer la pompe à l'extérieur de la structure à l'air frais. Garder tous les solvants loin de l'échappement du moteur. Ne jamais remplir le réservoir à carburant lorsque le moteur est en marche ou lorsqu'il est chaud ; les surfaces chaudes risquent d'enflammer le carburant déversé accidentellement. Toujours raccorder un fil de mise à la terre entre la pompe et un objet mis à la terre, tel qu'une conduite d'eau métallique. Se reporter au guide d'utilisation du moteur pour obtenir de plus amples renseignements concernant la sécurité.

DANGER: RISQUES D'EXPLOSION PAR INCOMPATIBILITÉ DES MATÉRIAUX - Peuvent être à l'origine de corporels sérieux ou dommages matériels.

MESURES PRÉVENTIVES:

- Ne pas utiliser de matériaux contenant des agents de blanchiment ou du chlore.
- Ne pas utiliser des solvants à base d'hydrocarbure halogéné tels que l'agent anticryptogamique, le chlorure de méthylène et le trichloro-éthane-1,1,1. Ces produits ne sont pas compatibles avec l'aluminium.
- Communiquer avec votre fournisseur de revêtement pour connaître la compatibilité du matériau avec l'aluminium.

DANGER: VAPEURS NOCIVES – la peinture, les solvants, les insecticides et autres matériaux peuvent être nocifs lorsqu'ils sont inhalés ou en contact avec le corps. Les vapeurs peuvent causer une nausée importante, des évanouissements ou un empoisonnement.

MESURES PRÉVENTIVES:

- Utiliser un respirateur ou un masque chaque fois qu'il y a des risques d'inhalation de vapeurs. Lire attentivement toutes les instructions se rapportant au masque pour vérifier que celui-ci vous assure une protection suffisante contre les vapeurs toxiques.
- Porter des lunettes de protection.
- Porter des vêtements de protection, conformément aux directives du fabricant de revêtement.

DANGER: GÉNÉRALITÉS - Peut causer des dommages matériels ou corporels sérieux.

MESURES PRÉVENTIVES:

- Avant d'utiliser tout équipement, lire attentivement toutes les instructions et les consignes de sécurité.
- Toujours débrancher le moteur de l'alimentation électrique avant d'effectuer des travaux sur l'appareil.
- Se conformer à la législation locale, provinciale ou fédérale pour tout ce qui concerne la ventilation, la prévention des incendies et les conditions générales d'utilisation.
- Les normes de sécurité du Gouvernement américain sont régies par le Occupational Safety and Health Act (OSHA). Il est important de consulter ces normes, en particulier la section 1910 sur les normes générales et la section 1926 sur les normes de la construction.
- N'utiliser que les pièces autorisées par le fabricant. L'utilisateur assume tous les risques et responsabilités lorsqu'il utilise des pièces qui ne sont pas conformes aux caractéristiques techniques minimales ainsi qu'aux dispositifs de sécurité du fabricant de la pompe.
- Vérifier, avant toute utilisation, que les flexibles ne présentent pas d'entaille ou de fuite, que le couvercle ne soit pas gonflé et que les raccords ne soient pas endommagés. Si le flexible a subi l'un des dommages précités, remplacez-le immédiatement. Ne jamais réparer un flexible d'alimentation en peinture. Le remplacer par un autre flexible mis à la terre.
- Tout flexible, raccord orientable, pistolet et accessoire utilisé avec cet appareil doit pouvoir fonctionner à une pression égale ou supérieure à 3300 lb/po² / 228BAR.
- Ne jamais pulvériser lorsqu'il vente.
- Porter des vêtements pour protéger la peau et les cheveux contre tout contact avec la peinture.

Instructions de mise à la terre

Cet appareil doit être mis à la terre. La mise à la terre réduit les risques d'électrocution lors d'un court-circuit en permettant au courant de s'écouler par le fil de mise à la terre. Cet appareil est muni d'un cordon électrique avec fil de mise à la terre ainsi que d'une fiche de terre. La fiche doit être branchée sur une prise installée correctement et mise à la terre conformément à la réglementation et aux codes en vigueur.

DANGER — Une prise de terre mal branchée peut être à l'origine d'électrocutions. S'il s'avère nécessaire de réparer ou de remplacer le cordon électrique ou la fiche, ne pas brancher le fil vert de mise à la terre sur l'une ou l'autre des bornes à broche plate. Le fil recouvert d'un isolant vert avec ou sans rayures jaunes est le fil de mise à la terre et doit être branché sur la broche de mise à la terre.

Si vous ne comprenez pas les instructions de mise à la terre ou si vous n'êtes pas sûr que l'appareil est correctement mis à la terre, contactez un électricien agréé. Ne pas modifier la fiche d'origine. Si la prise ne convient pas à la fiche, faites installer la prise adéquate par un électricien agréé.

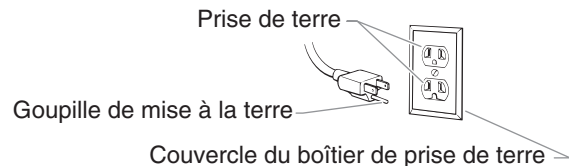

ATTENTION

Utiliser uniquement une rallonge à trois fils munie d'une fiche de terre dans une prise secteur mise à la terre correspondant au type de fiche de l'appareil. S'assurer que votre rallonge est en bon état. Lorsque vous utilisez une rallonge, assurez-vous qu'elle soit d'un calibre suffisant pour supporter l'intensité du courant requise par l'appareil. Une rallonge trop mince entraîne une chute de tension, une diminution de l'intensité et une surchauffe. Une rallonge de calibre 12 est recommandée. Si vous devez utiliser une rallonge à l'extérieur, celle-ci doit comprendre la marque W-A après la désignation indiquant le type de cordon. Par exemple, la désignation SJTW-A indique que le cordon est conçu pour être utilisé à l'extérieur.

Precauciones de seguridad

Este manual contiene información que debe leer y comprender antes de usar el equipo. Cuando se encuentre con uno de los siguientes símbolos, asegúrese de observar sus indicaciones de seguridad.

⚠ ADVERTENCIA

Este símbolo indica la existencia de un peligro potencial que puede causar lesiones graves o la muerte. Después del mismo se incluye información de seguridad importante.

⚠ PRECAUCION

Este símbolo indica la existencia de un peligro potencial para usted o el equipo. Después del mismo se incluye información importante que indica la forma de evitar daños al equipo o la forma de prevenir lesiones menores.

NOTA: los avisos contienen información importante, présteles especial atención.

⚠ ADVERTENCIA

PELIGRO: LESIÓN POR INYECCIÓN - La corriente de pintura de alta presión que produce este equipo puede perforar la piel y tejidos subyacentes, lo que conduciría a lesiones serias y una posible amputación. Consulte de inmediato a un médico.

NO TRATE LAS LESIONES POR INYECCIÓN COMO SI FUERAN SIMPLES CORTADAS! Una inyección puede conducir a una amputación. Consulte de inmediato a un médico.

El rango de operación máximo de la unidad es 3300 PSI / 228BAR de presión de fluidos.

PARA PREVENIR:

- NO dirija NUNCA la punta de la pistola hacia alguna parte del cuerpo.
- NO permita NUNCA que alguna parte del cuerpo tenga contacto con la corriente del fluido. EVITE tener contacto con corrientes de fluido que salgan de fugas que haya en la manguera.
- NO ponga NUNCA la mano enfrente de la manguera. Los guantes no ofrecen ninguna protección contra lesiones por inyección.
- Bloquee SIEMPRE el gatillo de la pistola, apague la bomba de fluido y libere toda la presión antes de dar mantenimiento, limpiar el protector de la boquilla, cambiar la boquilla o dejar desatendido el equipo. La presión no se liberará al apagar el motor. Para liberar la presión debe girarse la perilla PRIME/SPRAY (cebar/atomizar) hasta la posición PRIME. Consulte el PROCEDIMIENTO PARA LIBERAR LA PRESIÓN que se describe en este manual.
- Mantenga puesto SIEMPRE el protector de la boquilla mientras atomice. El protector de la boquilla ofrece cierta protección contra lesiones por inyección pero es principalmente un dispositivo de advertencia.
- Quite SIEMPRE la boquilla del atomizador antes de enjuagar o limpiar el sistema.
- Pueden desarrollarse fugas en la manguera de pintura por causa del desgaste, retorcimientos o el abuso. Una fuga es capaz de inyectar el material en la piel. Cada vez que use la manguera de pintura, inspecciónela antes.
- NO use nunca una pistola de atomización que no tenga un bloqueador o un protector de gatillo puesto y que funcione.
- Todos los accesorios deben tener una capacidad de 3300 lb/pulg² / 228BAR o mayor. Esto incluye las boquillas de atomizador, pistolas, extensiones y mangueras.

NOTA PARA EL MÉDICO: La inyección dentro de la piel es una lesión traumática. Es importante que la lesión se trate quirúrgicamente tan pronto como sea posible. NO retrase el tratamiento por investigar la toxicidad. La toxicidad es motivo de preocupación con algunos revestimientos que se inyectan directamente en la corriente sanguínea. Es recomendable consultar a un cirujano plástico o reconstructor de manos.

PELIGRO: EXPLOSIÓN O INCENDIO - Los vapores de solventes y pintura pueden explotar o incendiarse, causando con esto lesiones severas y/o daños en la propiedad.

PARA PREVENIR:

- Debe proveerse un escape y aire fresco para hacer que el aire que está dentro del área de atomización se mantenga libre de acumulaciones de vapores inflamables.
- Evite todas las fuentes de ignición como son las chispas electrostáticas, llamas abiertas, flamas de piloto, objetos calientes, cigarros, y chispas que se generan al conectar y desconectar las extensiones o de apagadores de luz que estén funcionando.
- No fume en la zona de trabajo.
- Debe haber un equipo para extinguir incendios permanentemente y en buenas condiciones.
- Coloque la bomba para pintar a un mínimo de 1 m (de preferencia más) en una habitación aparte, bien ventilada, alejada del objeto que va a pintar o a por lo menos 6 m de dicho objeto, en una zona bien ventilada (utilice una manguera más larga, si es necesario). Los gases inflamables a menudo son más pesados que el aire. La zona del piso debe tener la debida ventilación. La bomba para pintar contiene piezas que forman arcos que emiten chispas y pueden encender los gases.
- El equipo que se utilice, así como los objetos que estén dentro y alrededor del área de atomización, deben conectarse a tierra de manera apropiada para prevenir las descargas eléctricas y las chispas.
- Use solamente mangueras para fluidos de alta presión, conductoras o conectadas a tierra, para aplicaciones sin aire. Asegúrese de que la pistola esté conectada a tierra de manera apropiada, mediante conexiones de manguera.
- El cable de alimentación debe enchufarse a un circuito aterrado.
- Siempre enjuague la unidad en un recipiente de metal por separado, con presión baja en la bomba y sin la boquilla. Sostenga la pistola firmemente contra el recipiente para ponerlo a tierra y evitar chispas estáticas.
- Siga las advertencias y avisos de seguridad del fabricante de los materiales y solventes.
- Tenga muchísimo cuidado al usar materiales cuyo punto de ignición sea inferior a 70° F (21° C). El punto de ignición es la temperatura a la cual pueden encenderse los vapores emanados por un fluido al exponerlos a llamas o chispas.
- El plástico puede causar chispas estáticas. Nunca cuelgue plástico en las ventanas ni en las puertas del área donde va a pintar. No utilice plástico para proteger el piso cuando pinte materiales inflamables.
- Cuando enjuague el equipo utilice la presión más baja posible.

MOTOR DE GAS (SEGÚN CORRESPONDA)

Coloque siempre la bomba fuera del edificio, al aire libre. Mantenga todo solvente alejado del escape del motor. Nunca llene el tanque de combustible si el motor está encendido o caliente. La superficie caliente puede encender el combustible derramado. Conecte siempre un conductor de tierra desde la unidad de la bomba a un objeto puesto a tierra, por ejemplo una tubería de agua metálica. Consulte el manual del motor para obtener información completa de seguridad.

PELIGRO: PELIGRO DE EXPLOSIÓN DEBIDO A MATERIALES INCOMPATIBLES - Podría causar lesiones severas o daños en la propiedad.

PARA PREVENIR:

- No utilice materiales que contengan blanqueador o cloro.
- No use solventes con hidrocarburos halogenados, tales como productos para eliminar el moho, cloruro de metileno y 1,1,1 - tricloroetano. Estos no son compatibles con el aluminio.
- Comuníquese con el proveedor del producto para obtener información de compatibilidad con materiales de aluminio.

PELIGRO: GASES PELIGROSOS - Las pinturas, solventes, insecticidas y otros materiales pueden ser perjudiciales si se inhalan o entran en contacto con el cuerpo. Los gases pueden causar náusea, desmayos o envenenamiento graves.

PARA PREVENIR:

- Use una mascarilla respiratoria o careta siempre que exista la posibilidad de que se puedan inhalar vapores. Lea todas las instrucciones que vengan con la careta para estar seguro de que se tendrá la protección necesaria contra la inhalación de vapores dañinos.
- Use gafas protectoras.
- Use ropa de protección, según lo requiera el fabricante del producto.

PELIGRO: GENERAL - Puede causar daños en la propiedad o lesiones severas.

PARA PREVENIR:

- Lea todas las instrucciones y advertencias de seguridad antes de hacer funcionar cualquier equipo.
- Desconecte siempre el motor del suministro eléctrico antes de dar servicio al equipo.
- Observe todos los códigos locales, estatales y nacionales apropiados que rigen las medidas de ventilación, prevención de incendios y operación.
- Los Estándares de Seguridad del Gobierno de los Estados Unidos se han adoptado bajo el Acta de Seguridad y Salud Ocupacionales (OSHA por sus siglas en inglés). Deben consultarse estos estándares, particularmente la parte 1910 de los Estándares Generales y la parte 1926 de los Estándares de la Construcción.
- Utilice únicamente piezas autorizadas por el fabricante. El usuario asume todos los riesgos y responsabilidades si usa piezas que no cumplen con las especificaciones mínimas y dispositivos de seguridad del fabricante de la bomba.
- Antes de usarla cada vez, revise todas las mangueras para ver que no tengan cortadas, fugas, una cubierta desgastada por abrasión o con abolladuras, así como uniones dañadas o que se hayan movido. Si existiera cualquiera de estas condiciones, reemplace la manguera inmediatamente. No repare nunca una manguera de pintura. Reemplácela con otra manguera conectada a tierra.
- Todas las mangueras, soportes giratorios, pistolas y accesorios que se usen con esta unidad deben tener una capacidad de presión de 3300 lb/pulg² / 228 BAR o mayor.
- No atomice en días con viento.
- Use ropa que evite el contacto de la pintura con la piel y el cabello.

Instrucciones para conectar a tierra

Este producto se debe conectar a tierra. En caso de que ocurra un corto circuito, la conexión a tierra reduce el riesgo de choque eléctrico al proporcionar un alambre de escape para la corriente eléctrica. Este producto está equipado con un cable que tiene un alambre de conexión a tierra con un enchufe de conexión a tierra apropiado. El enchufe se debe enchufar en una toma de corriente que se haya instalado y conectado a tierra debidamente, de acuerdo con todos los códigos y estatutos locales.

PELIGRO — Una instalación inapropiada del enchufe de conexión a tierra puede dar como resultado el que exista un riesgo de choque eléctrico. Si es necesario reparar o reemplazar el cable o el enchufe, no conecte el alambre de conexión a tierra a ninguno de los terminales de hoja planas. El alambre con aislamiento que tiene la superficie exterior de color verde con franjas amarillas o sin ellas es el alambre de conexión a tierra que debe conectarse al conector de conexión a tierra.

Verifique con un electricista o técnico de servicio calificado si las instrucciones para conectar a tierra no le han quedado completamente claras, o si duda que el producto haya quedado conectado a tierra de manera apropiada. No modifique el enchufe que se proporciona. Si el enchufe no entra en la toma de corriente, pídale a un electricista calificado que instale la toma apropiada.

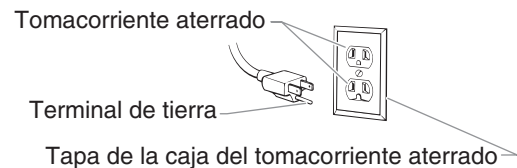

PRECAUCION

Use solamente extensiones trifilares que tengan un enchufe de conexión a tierra de 3 hojas y un receptáculo de triple ranura que acepte el enchufe del producto. Asegúrese de que su extensión esté en buenas condiciones. Cuando use una extensión, asegúrese de usar una que sea lo suficientemente resistente como para soportar la corriente que descargue su producto. Un cable de un tamaño menor causará una caída de voltage en la línea que dará como resultado una pérdida de energía y un sobrecalentamiento. Se recomienda usar un cable de calibre 12. Si se utiliza un cable de extensión en el exterior, tiene que estar marcado con el sufijo W-A después de la designación del tipo de cable. Por ejemplo, SJTW-A para indicar que el cable es apropiado para uso en exteriores.

Parts List

Main Assembly

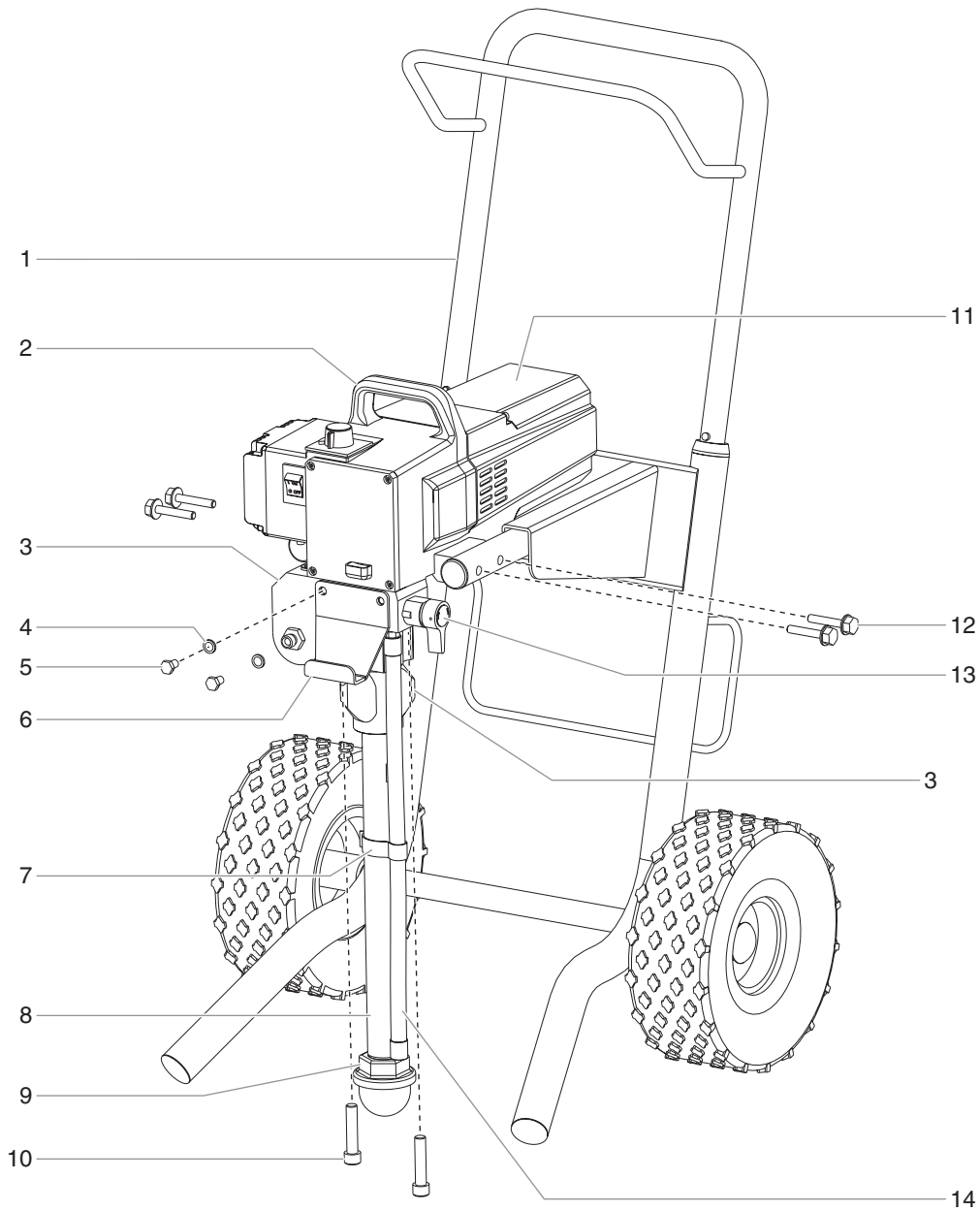

<u>Item</u>	<u>Part #</u>	<u>Description</u>	<u>Quantity</u>
1	800-570	High Rider cart assembly	1
2	-----	Gear box assembly (see separate listing) ..	1
3	-----	Fluid section assembly (see separate listing)	1
4	763-552	Lock washer	2
5	710-033	Screw	2
6	704-304	Pail hook	1
7	730-334	Hose clamp	1

<u>Item</u>	<u>Part #</u>	<u>Description</u>	<u>Quantity</u>
8	705-054	Siphon tube (High Rider)	1
9	710-046	Inlet screen, 10 mesh (High Rider)	1
10	704-117	Screw	2
11	-----	Motor assembly (see separate listing)	1
12	761-178	Screw	4
13	800-915	PRIME/SPRAY valve assembly	1
14	702-239	Return hose (High Rider)	1

Motor Assembly

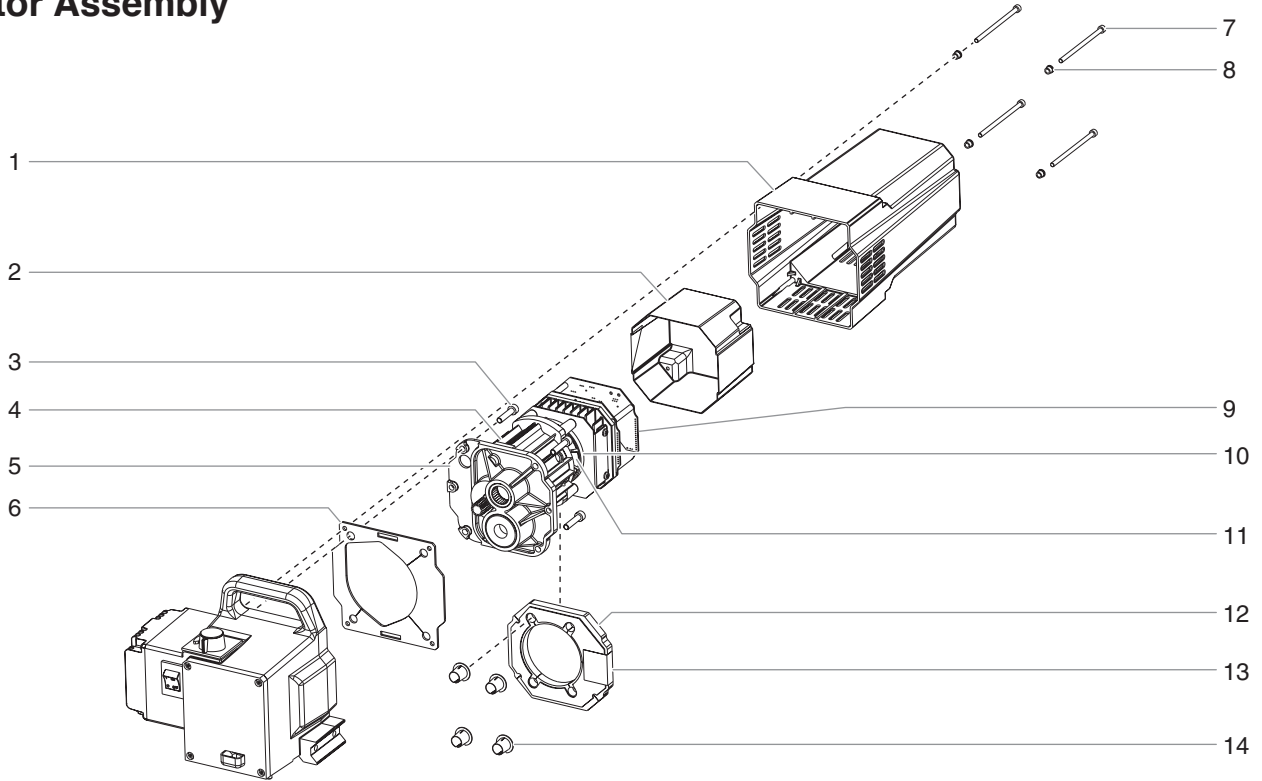

Item	Part #	Description	Quantity	Item	Part #	Description	Quantity
1	800-465	Motor shroud.....	2	8	704-332	Screw grommet.....	4
2	705-063	Electronic cover	1	9	800-213	Electronic control assembly, 120V.....	1
3	700-681	Screw.....	4	10	800-215	Fan shroud.....	1
4	800-211	Motor assembly, 120V (includes items 5 and 9-11)	1	11	800-294	Fan assembly	1
5	800-209	Front end bell assembly w/bearings.....	1	12	800-427	Baffle assembly	1
6	704-331	Housing gasket.....	1	13	800-416	Baffle tape.....	1
7	704-181	Screw.....	4	14	800-439	Baffle spacer.....	4

Electrical Schematic

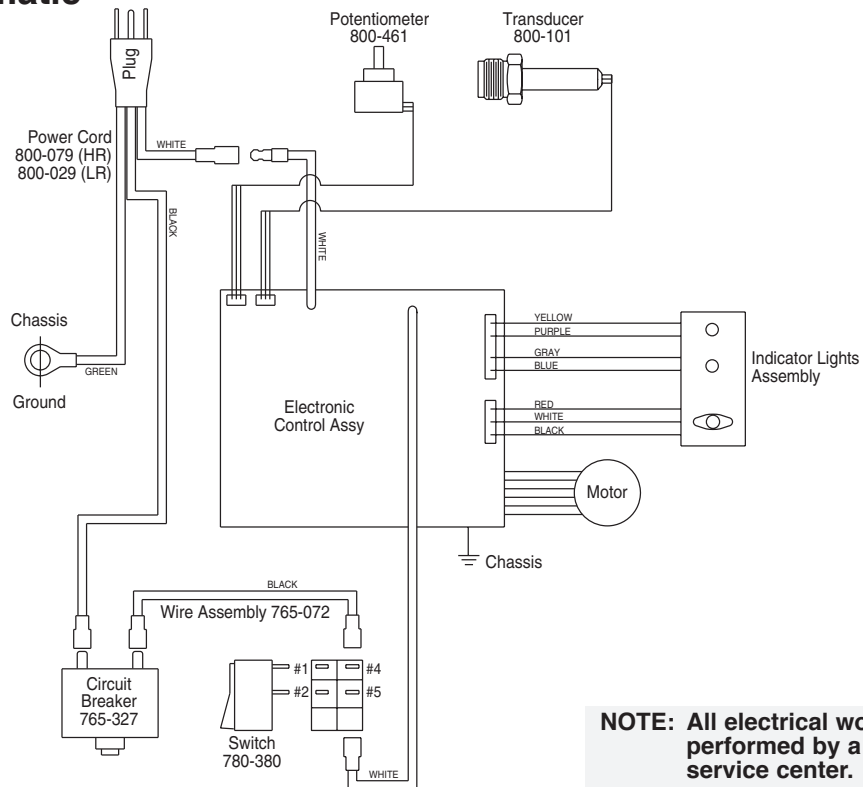

NOTE: All electrical work should be performed by a Titan authorized service center.

Gear Box Assembly

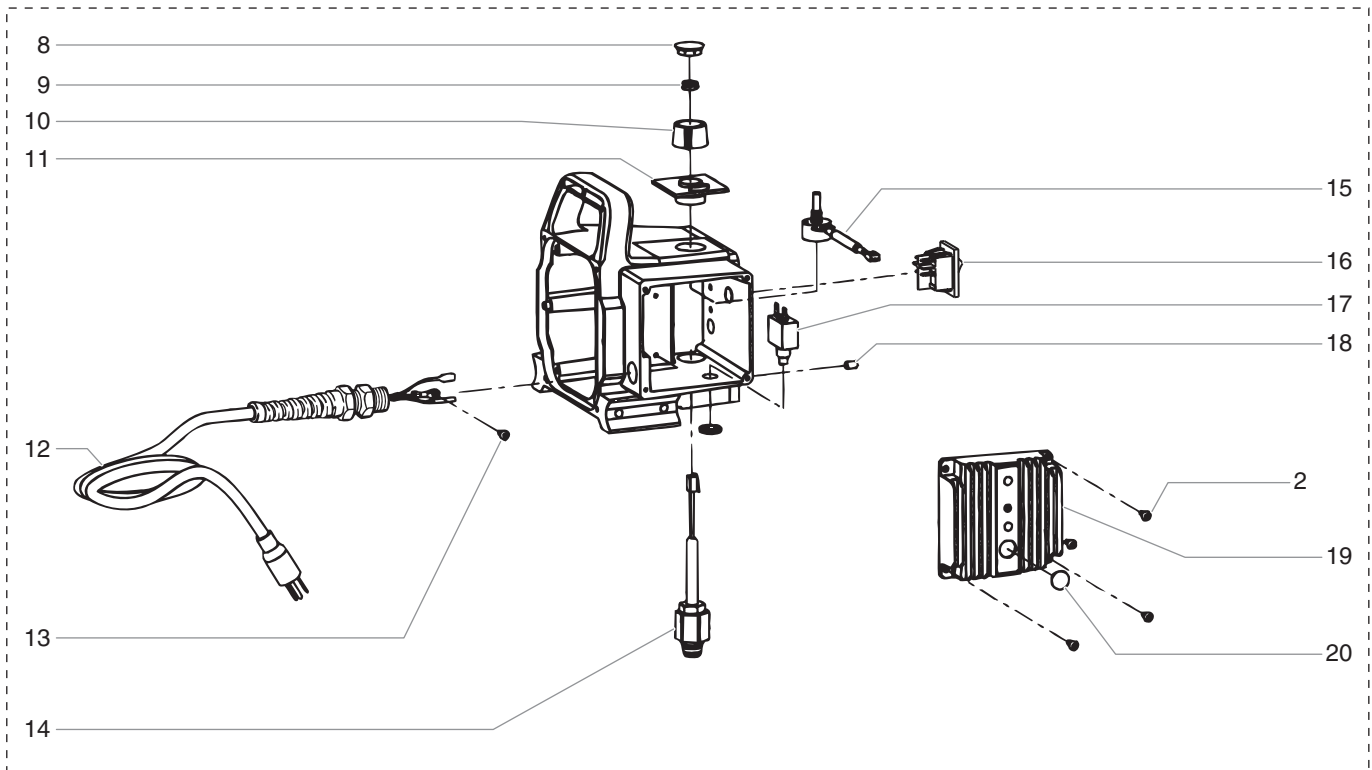
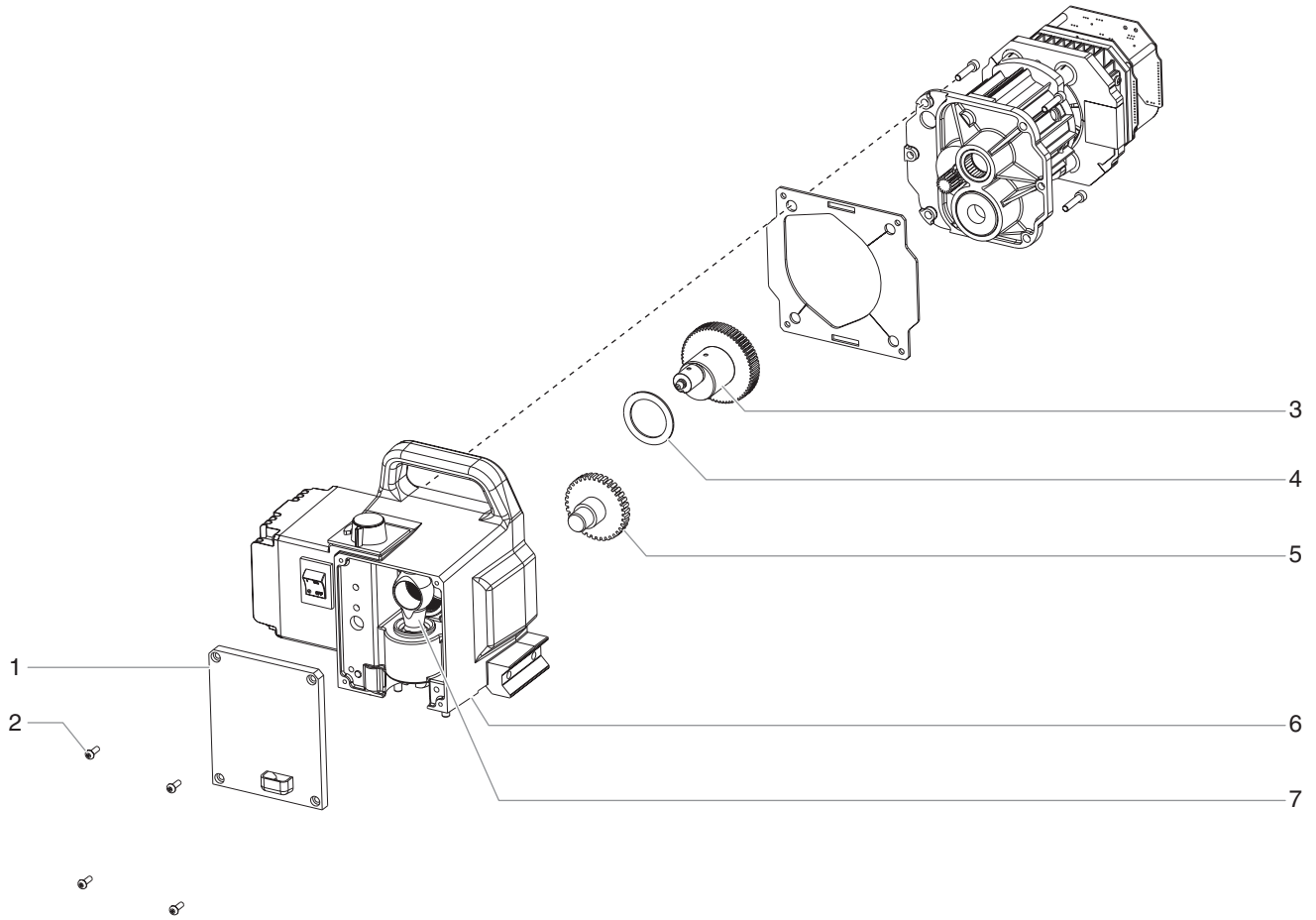

Item	Part #	Description	Quantity
1	800-464	Front cover w/label	1
2	700-139	Screw	8
3	704-173	Crankshaft/gear assembly	1
4	704-174	Thrust washer	1
5	704-176	2nd stage gear	1
6	800-067	Gear box housing	1
7	704-301	Slider assembly	1
8	700-175	Cap	1
9	700-176	Seal	1
10	700-159	Pressure control knob	1
11	800-274	Potentiometer mount	1

Item	Part #	Description	Quantity
12	800-079	Power cord assembly (high rider)	1
	800-029	Power cord assembly (low rider)	1
13	704-229	Screw	1
14	800-101	Transducer assembly	1
15	800-461	Potentiometer	1
16	704-380	ON/OFF switch	1
17	765-327	Circuit breaker	1
18	710-127	Set screw	1
19	800-460	Heat sink assembly (includes item 21)	1
20	704-281	Port plug	1

High Rider Cart Assembly (P/N 800-570)

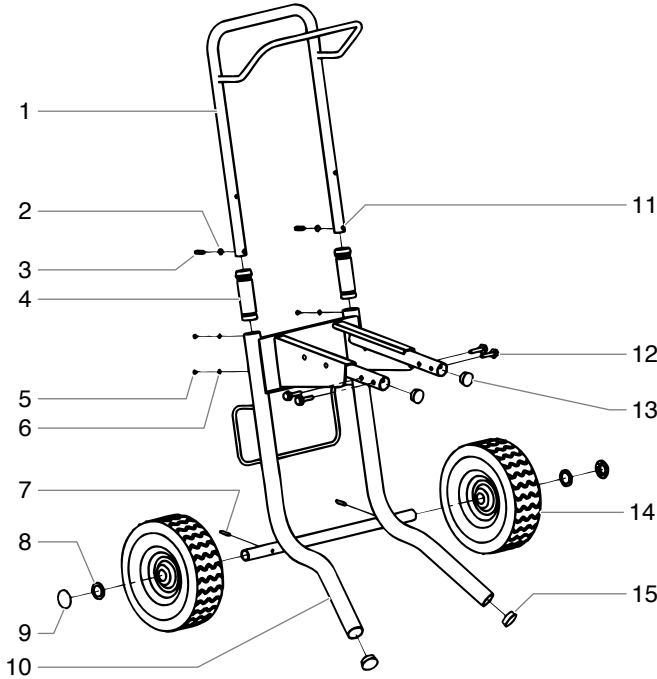

Item	Part #	Description	Quantity
1	800-463	Handle (includes items 2-6 and 11)	1
2	590-506	Washer	2
3	590-508	Roll pin	2
4	590-504	Sleeve	2
5	856-921	Screw	4
6	856-002	Washer	4
7	704-291	Roll pin	2
8	704-354	Spacer	2
9	704-355	Cap	2
10	800-462	Frame (includes items 13 and 15)	1
11	590-507	Snap button	2
12	761-178	Hex head screw	4
13	710-199	Plug	2
14	800-593	Wheel	2
15	335-018	Plug	2

Low Rider Cart Assembly (P/N 705-200)

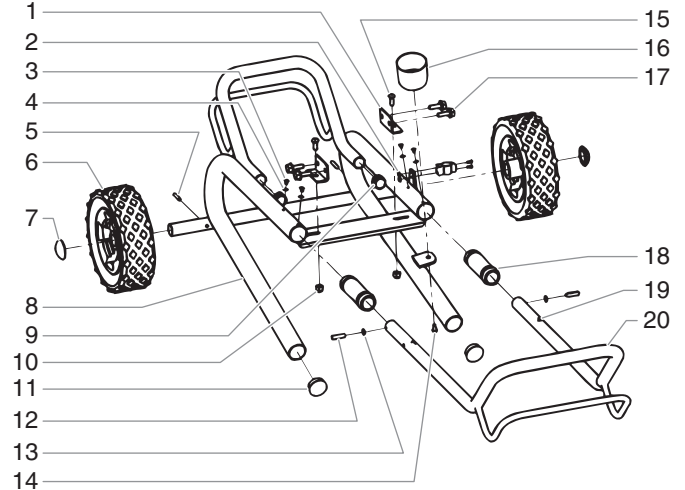

Item	Part #	Description	Quantity
1	704-307	Mounting bracket	2
2	763-549	Hex lock nut	2
3	856-921	Screw	4
4	856-002	Washer	4
5	704-291	Roll pin	2
6	800-468	Wheel	2
7	704-355	Cap	2
8	800-470	Frame (includes items 9 and 11)	1
9	700-674	Cap	2
10	763-549	Lock nut	2
11	335-018	Plug	2
12	590-508	Roll pin	2
13	590-506	Washer	2
14	704-188	Screw	1
15	773-918	Screw	2
16	700-1041	Drip cup	1
17	756-091	Hex head screw	4
18	590-504	Sleeve	2
19	590-507	Snap button	2
20	800-469	Handle assembly (includes items 1, 3, 4, 12, 13, 18, and 19)	1
21	704-354	Wheel spacer (not shown)	4

Fluid Section Assembly

NOTE: When using "HOT" solvents, replace Viton o-ring (item 36) with optional PTFE o-ring (P/N 700-897). Install with o-ring tool (P/N 700-890).

Install upper packing with raised lip and o-ring facing down.

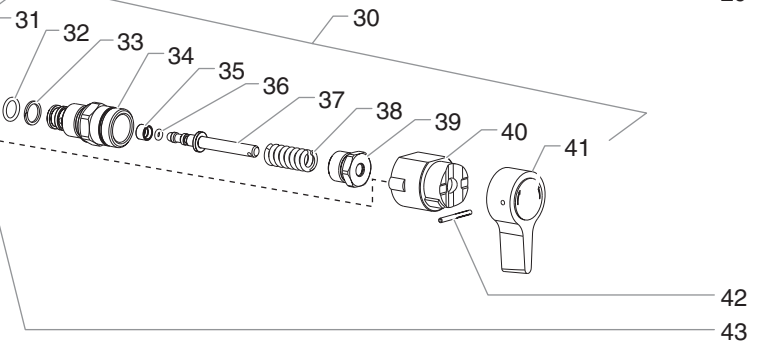
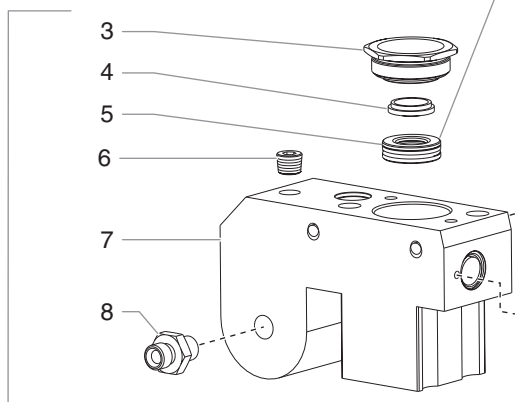
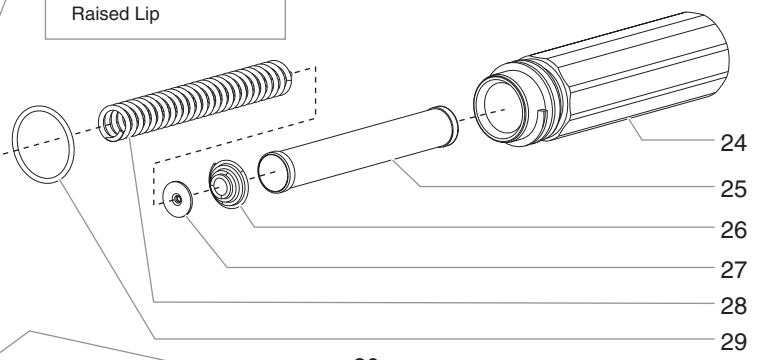
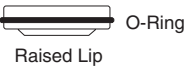

Install lower packing with the side that has the o-ring closest to the top of the packing facing up.

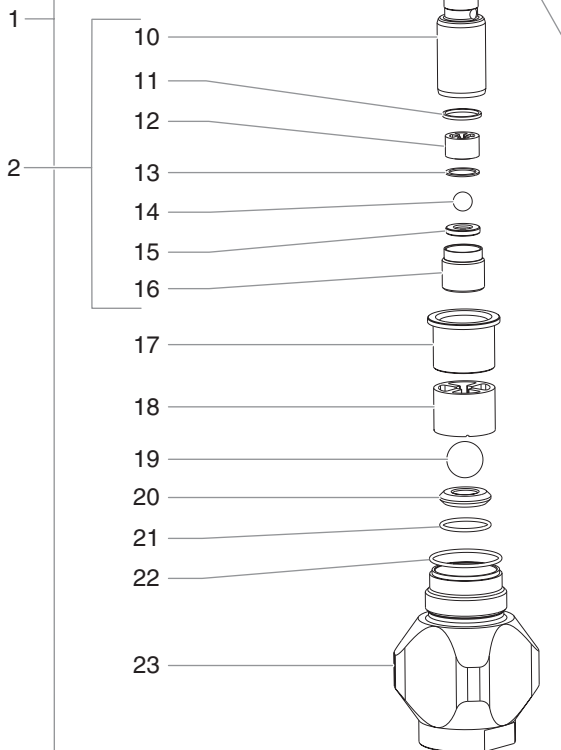

NOTE: When repacking the fluid section, make sure the raised lip on the bottom of the lower packing is fully outside the packing around the piston rod after insertion of the piston rod.

Item	Part #	Description	Quantity	Item	Part #	Description	Quantity
1	800-458	Fluid section, High Rider (excludes items 24–41)	1	27	702-251	Adapter	1
	800-466	Fluid section, Low Rider (excludes items 24–41)	1	28	757-105	Filter support spring	1
2	800-451	Piston assembly (includes items 10–16)	1	29	704-297	O-ring	1
3	705-104	Retainer nut	1	30	800-915	PRIME/SPRAY valve assembly (includes items 31–43)	1
4	705-105	Piston guide	1	31	700-537	Gasket	1
5	800-454	Upper packing assembly	1	32	221-012	O-ring, Viton	1
6	227-028	Plug	1	33	222-012	O-ring, PTFE	1
7	800-453	Pump block (includes item 6)	1	34	700-253	Valve housing	1
8	227-006	Outlet fitting	1	35	800-910	Valve seat	1
9	800-456	Lower packing assembly	2	36	700-721	O-ring, Viton	1
10	800-452	Piston rod	1		700-897	O-ring, PTFE (optional)	1
11	800-348	Upper seal	1	37	700-750	Valve stem	1
12	800-441	Upper cage	1	38	800-926	Spring	1
13	800-245	Nylon washer	1	39	700-248	Valve retainer	1
14	800-247	Outlet valve ball	1	40	700-251	Cam base	1
15	800-243	Outlet valve seat	1	41	700-697	Valve handle	1
16	800-336	Outlet valve retainer	1	42	700-759	Groove pin	1
17	705-103	Adapter	1	43	700-823	Dowel pin	1
18	800-442	Lower cage	1	44	704-273	Fitting (Low Rider only, not shown)	1
19	800-242	Foot valve ball	1		800-459	Fluid section complete, high rider (includes items 1–43)	1
20	800-241	Foot valve seat	1		800-467	Fluid section complete, low rider (includes items 1–44)	1
21	762-058	O-ring	1		800-450	Repacking kit (includes items 4, 5, 9, 11, 13, 14, 17, 19, and 20–22, as well as packing grease P/N 700-203 and lower packing insertion tool P/N 705-138)	1
22	762-103	Lower seal	1		705-138	Lower packing insertion tool	1
23	705-106	Foot valve housing (High Rider)	1				
	705-141	Foot valve housing (Low Rider)	1				
24	704-252	Filter housing	1				
25	730-067	Filter	1				
26	730-083	Filter spring	1				

Suction Set Assembly, Low Rider (P/N 704-300)

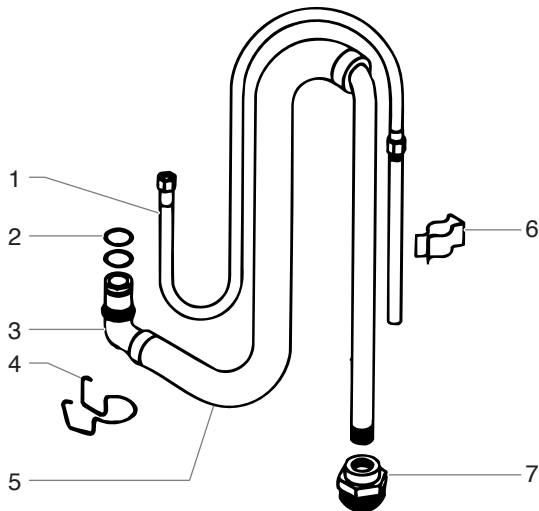

Item	Part #	Description	Quantity
1	704-263	Return hose assembly	1
2	704-121	O-ring	2
	704-109	O-ring (for hot solvents, optional)	1
3	700-1024	Elbow	1
4	704-127	Retaining clip	1
5	700-1023	Siphon hose (includes items 2–4, and 7)	1
6	755-135	Clip	1
7	700-805	Inlet screen	1

Accessories

Airless Tip Selection

Tips are selected by the orifice size and fan width. The proper selection is determined by the fan width required for a specific job and by the orifice size that will supply the desired amount of fluid and accomplish proper atomization.

For light viscosity fluids, smaller orifice tips generally are desired. For heavier viscosity materials, larger orifice tips are preferred. Please refer to the chart below.

NOTE: Do not exceed the sprayer's recommended maximum tip size.

The following chart indicates the most common sizes and the appropriate materials to be sprayed.

Tip Size	Spray Material	Filter Type
.011 — .013	Lacquers and stains	100 mesh filter
.015 — .019	Oil and latex	60 mesh filter
.021 — .026	Heavy bodied latex and blockfillers	30 mesh filter

Fan widths measuring 8" to 12" (20 to 30 cm) are preferred because they offer more control while spraying and are less likely to plug.

Liquid Shield Plus

Cleans and protects spray systems against rust, corrosion and premature wear. Now with -25° anti-freeze protection.

Part #	Description
314-483	4 ounce bottle
314-482	1 quart bottle

Piston Lube

Specially formulated to prevent materials from adhering to the piston rod, which becomes abrasive to the upper seals. Piston Lube will break down any material that may accumulate in the oil cup and keep it from drying.

Part #	Description
314-481	4 ounce bottle
314-480	8 ounce bottle

Miscellaneous

Part #	Description
490-012	Hose coupling, 1/4" x 1/4"
730-397	High pressure fluid Gauge
314-171	Lubriplate, 14 ounce individual
314-172	Lubriplate, 6 lb. can
700-1037	Electrostatic discharge (ESD) wrist strap

Labels

Part #	Description
313-1691	740i logo label
313-1673	Warning label (injection/explosion)
313-1847	Shock hazard label
313-1715	Pressure control knob label
313-1743	Indicator lights label
313-1638	"Titan" front label
313-1906	Infinity logo label

Warranty

Titan Tool, Inc., ("Titan") warrants that at the time of delivery to the original purchaser for use ("End User"), the equipment covered by this warranty is free from defects in material and workmanship. With the exception of any special, limited, or extended warranty published by Titan, Titan's obligation under this warranty is limited to replacing or repairing without charge those parts which, to Titan's reasonable satisfaction, are shown to be defective within twelve (12) months after sale to the End User. This warranty applies only when the unit is installed and operated in accordance with the recommendations and instructions of Titan.

This warranty does not apply in the case of damage or wear caused by abrasion, corrosion or misuse, negligence, accident, faulty installation, substitution of non-Titan component parts, or tampering with the unit in a manner to impair normal operation.

Defective parts are to be returned to an authorized Titan sales/service outlet. All transportation charges, including return to the factory, if necessary, are to be borne and prepaid by the End User. Repaired or replaced equipment will be returned to the End User transportation prepaid.

THERE IS NO OTHER EXPRESS WARRANTY. TITAN HEREBY DISCLAIMS ANY AND ALL IMPLIED WARRANTIES INCLUDING, BUT NOT LIMITED TO, THOSE OF MERCHANTABILITY AND FITNESS FOR A PARTICULAR PURPOSE, TO THE EXTENT PERMITTED BY LAW. THE DURATION OF ANY IMPLIED WARRANTIES WHICH CANNOT BE DISCLAIMED IS LIMITED TO THE TIME PERIOD SPECIFIED IN THE EXPRESS WARRANTY. IN NO CASE SHALL TITAN LIABILITY EXCEED THE AMOUNT OF THE PURCHASE PRICE. LIABILITY FOR CONSEQUENTIAL, INCIDENTAL OR SPECIAL DAMAGES UNDER ANY AND ALL WARRANTIES IS EXCLUDED TO THE EXTENT PERMITTED BY LAW.

TITAN MAKES NO WARRANTY AND DISCLAIMS ALL IMPLIED WARRANTIES OF MERCHANTABILITY AND FITNESS FOR A PARTICULAR PURPOSE WITH RESPECT TO ACCESSORIES, EQUIPMENT, MATERIALS OR COMPONENTS SOLD BUT NOT MANUFACTURED BY TITAN. THOSE ITEMS SOLD, BUT NOT MANUFACTURED BY TITAN (SUCH AS GAS ENGINES, SWITCHES, HOSES, ETC.) ARE SUBJECT TO THE WARRANTY, IF ANY, OF THEIR MANUFACTURER. TITAN WILL PROVIDE THE PURCHASER WITH REASONABLE ASSISTANCE IN MAKING ANY CLAIM FOR BREACH OF THESE WARRANTIES.

Material Safety Data Sheets (MSDS) are available on Titan's website or by calling Customer Service.



United States Sales & Service
1-800-526-5362
Fax 1-800-528-4826

107 Bauer Drive
 Oakland, NJ 07436
www.titantool.com

Canadian Branch
1-800-565-8665
Fax 1-905-856-8496

200 Trowers Road, Unit 7B
 Woodbridge, Ontario L4L 5Z8

International
1-201-337-1240
Fax 1-201-405-7449

107 Bauer Drive
 Oakland, NJ 07436 USA