

SpecSeal®

QC

PERIMETER FIRE CONTAINMENT PROTECTION

Quick Clip™ Perimeter Fire Containment System

SpecSeal® Quick Clip™ Perimeter Fire Containment System is designed to accelerate the installation of curtain wall insulation for perimeter fire containment systems. The system's unique U-brackets clip onto the mullions without direct attachment by screws to support the curtain wall insulation. Self-locking fasteners secure the insulation panels in place. Each U-bracket has a receiving slot to lock an "L-shaped" stiffener channel in place without the need for mechanical attachment by screws.

Features & Benefits

- Tested to ASTM E1233 for 100 MPH+ wind-loads
- Reduce or eliminate use of steel screws into framing members
- Tested for up to 2 Hours of fire resistance when tested to ASTM E2307

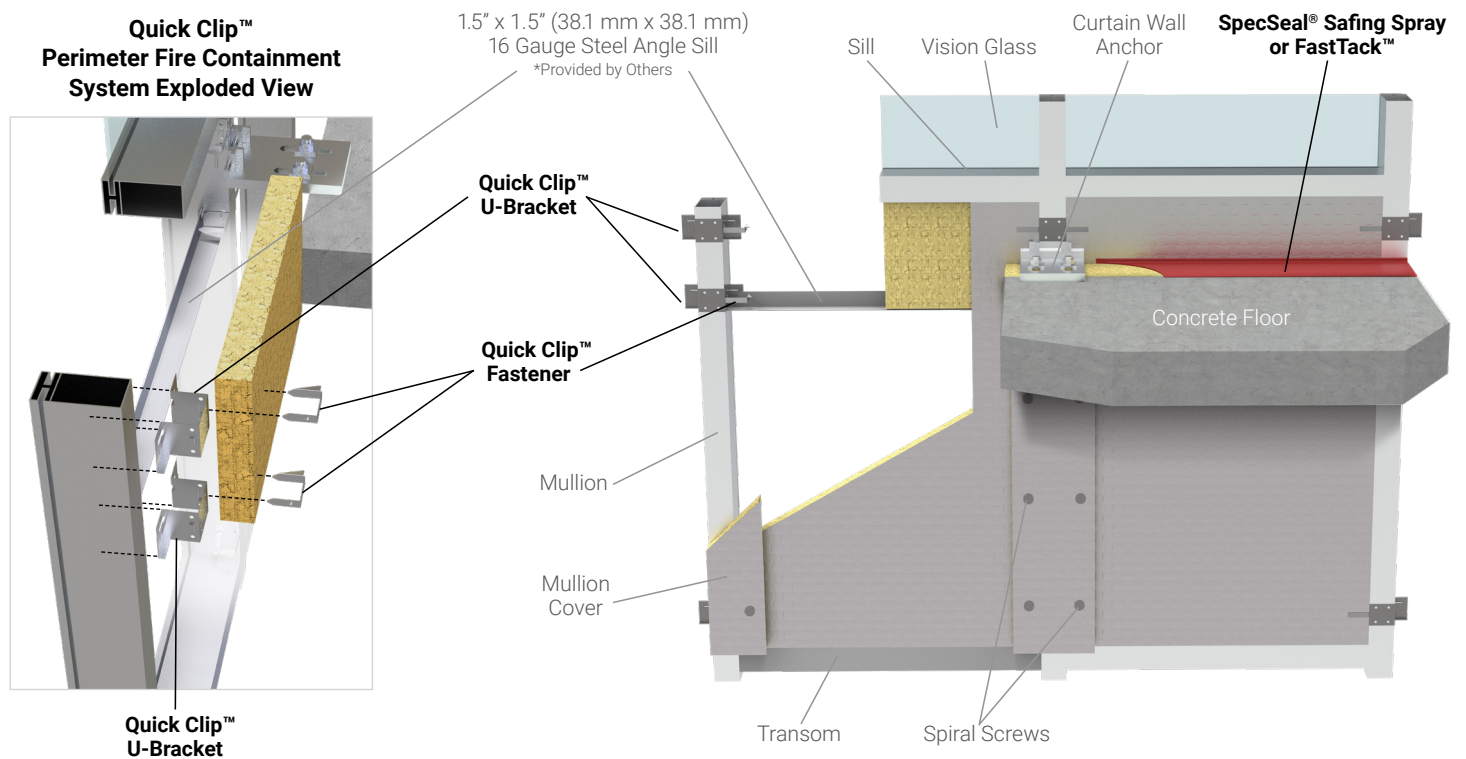
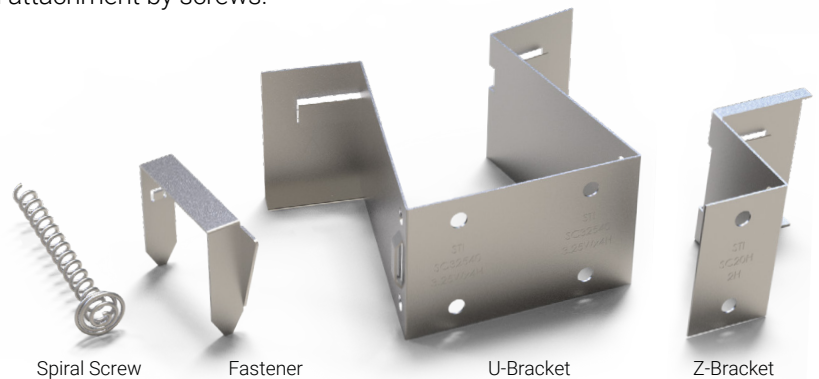

Patent Numbers: 10329761, 10329762, 10626603, 10724233







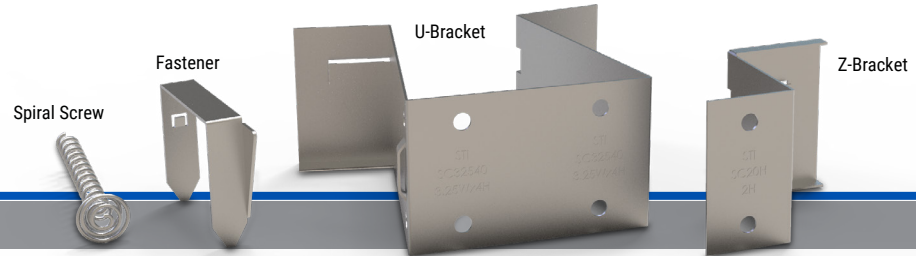

SpecSeal™
QC

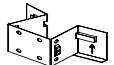
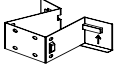
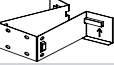
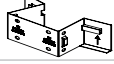
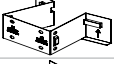
PERIMETER FIRE CONTAINMENT PROTECTION

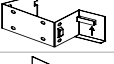
Quick Clip™ Perimeter Fire Containment System

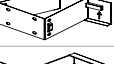

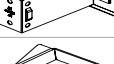
ORDERING INFORMATION

Catalog Number	UPC Number	Description	Product Image	Mullion Width		Insulation	Weight (Each)	Case Qty.	Material
				Min.	Max.				
SC25020	730573100011	Quick Clip™ U-Bracket*				2" (50.8 mm)	0.31 lbs (0.14 kg)	100	Heat treated galvanized steel
SC25030	730573100028	Quick Clip™ U-Bracket*		2.375" (60.3 mm)	2.525" (65.1 mm)	3" (76.2 mm)	0.30 lbs (0.14 kg)	100	
SC25040	730573100035	Quick Clip™ U-Bracket*				4" (101.6 mm)	0.35 lbs (0.16 kg)	100	
SC30020	730573100042	Quick Clip™ U-Bracket				2" (50.8 mm)	0.28 lbs (0.13 kg)	100	Heat treated galvanized steel
SC30030	730573100059	Quick Clip™ U-Bracket		2.875" (73 mm)	3.2" (81.2 mm)	3" (76.2 mm)	0.32 lbs (0.15 kg)	100	
SC30040	730573100066	Quick Clip™ U-Bracket				4" (101.6 mm)	0.37 lbs (0.17 kg)	100	
SC32520	730573100073	Quick Clip™ U-Bracket				2" (50.8 mm)	0.28 lbs (0.13 kg)	100	Heat treated galvanized steel
SC32530	730573100080	Quick Clip™ U-Bracket		3.125" (79.4 mm)	3.45" (87.6 mm)	3" (76.2 mm)	0.34 lbs (0.15 kg)	100	
SC32540	730573100097	Quick Clip™ U-Bracket				4" (101.6 mm)	0.38 lbs (0.17 kg)	100	
SC20H	730573100103	Quick Clip™ Z-Bracket				2" (50.8 mm)	0.13 lbs (0.06 kg)	100	Galvanized steel
SC30H	730573100110	Quick Clip™ Z-Bracket		All	All	3" (76.2 mm)	0.15 lbs (0.07 kg)	100	
SC40H	730573100127	Quick Clip™ Z-Bracket				4" (101.6 mm)	0.14 lbs (0.06 kg)	100	
SB2020	730573100257	Quick Clip™ Fastener		All	All	All	0.04 lbs (0.02 kg)	100	Galvanized steel
SA375	730573100264	Quick Clip™ Spiral Screw		All	All	All	0.02 lbs (0.01 kg)	1000	Galvanized steel

TEST STANDARDS: ASTM E1233, ASTM E2307



ORDERING INFORMATION - PERIMETER FIRE CONTAINMENT FIRESTOP SPRAY

Catalog Number	UPC Number	Description	(UOM) Qty.	Case Qty.	Weight (Each)
SFS105	730573071175	5 gallon pail - 1,155 cu. in. (19 liters) SpecSeal® Safing Spray for Perimeter Fire Containment	1	1	56.00 lbs (25.40 kg)
FT305	730573011904	SpecSeal® Fast Tack® Firestop Spray 5 gallon pail - 1,155 cu. in. (19 liters)	1	1	51.33 lbs (23.28 kg)
FT305R	730573011935	SpecSeal® Fast Tack® Firestop Spray 5 gallon pail - 1,155 cu. in. (19 liters)	1	1	51.33 lbs (23.28 kg)

* For single extrusion mullions only



1-800-992-1180
stifirestop.com



[Click here to learn more about](#)



ZSTI3499-34021