

MasterSeal® AWB 660 / AWB 660 I

Concrete / Masonry incorporating Fluid-Applied Vapor Permeable and Impermeable Air/Water-Resistive Barriers

TABLE OF CONTENTS

2. Typical Control or Expansion Joint (MasterSeal AWB 970 FIB Only)
2. Typical Control or Expansion Joint (Backer Rod & Sealant Only)
3. Typical Control or Expansion Joint (MasterSeal AWB 970 FIB with Backer Rod & Sealant)
3. Typical Rough Opening Treatment
4. Typical Penetration through Wall Construction
4. Typical Penetration through Wall Construction (with Fabric Only)
5. Typical Rough Opening Treatment with Blocking and Sheathing Fabric
5. Typical Rough Opening Treatment with Blocking and MasterSeal AWB 970 FIB
6. Typical Termination at Grade - Masonry Veneer
6. Typical EIFS Abutment to Brick with Continuous Insulation
7. Typical Termination at Foundation with Brick incorporating Through Wall Flashing - Termination Bar
7. Typical Termination at Foundation with Brick incorporating Through Wall Flashing - MasterSeal AWB 970 FIB
8. Typical Inside Corner
8. Typical Outside Corner
9. Typical Inside Corner Change in Substrate
9. Typical Termination at Floorline- Brick Shelf Angle
10. Typical Through Wall Flashing at Head
10. Typical Window Jamb
11. Typical Window Head
11. Typical Window Sill
12. Typical Roof Edge or Parapet Cap Flashing

NOTES:

- Install BASF materials in accordance with current installation instructions.
- Unsatisfactory conditions shall be reported to the General Contractor and corrected before the application of MasterSeal AWB products.
- The details within represent BASF Corporation - Construction Systems (hereinafter BASF Construction Systems) latest recommendations. They are presented in good faith by BASF Construction Systems. The details are subject to change without notice. BASF Construction Systems accepts no liability for the end use of the details. For conditions not shown, consult BASF Construction Systems for review of specific detail.

TYPICAL CONTROL OR EXPANSION JOINT (MASTERSEAL AWB 970 FIB ONLY)

NOTES

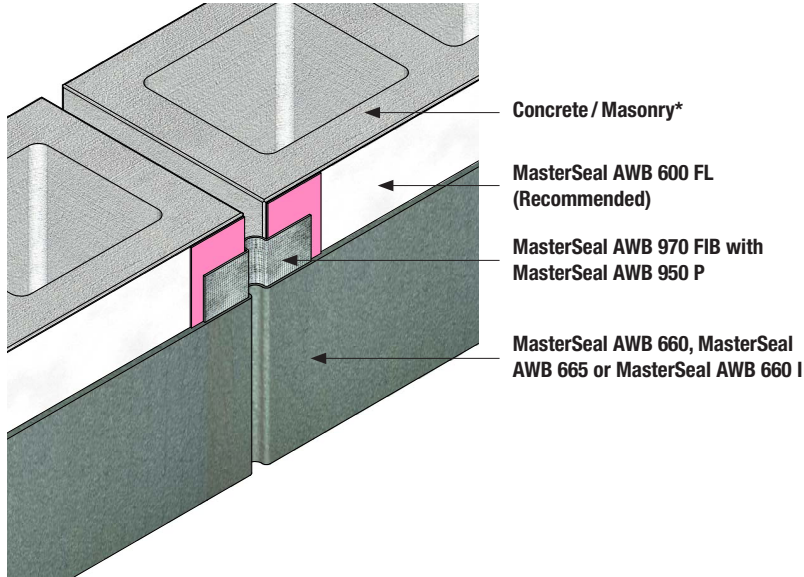

TYPICAL CONTROL OR EXPANSION JOINT (BACKER ROD AND SEALANT ONLY)

NOTES

- MasterSeal AWB 660 or MasterSeal AWB 665 or MasterSeal AWB 660 I is not required on sealant joint.

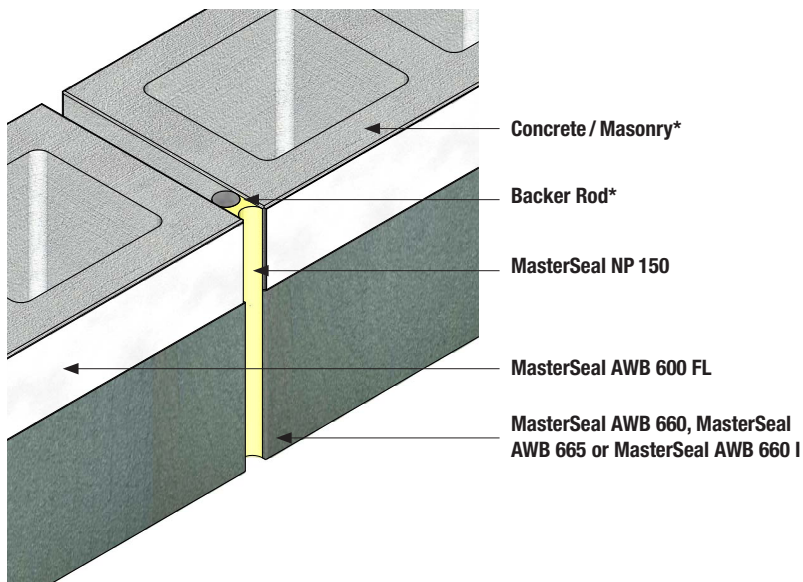

* By Others

NOTES

**TYPICAL CONTROL OR EXPANSION JOINT
 (MASTERSEAL AWB 970 FIB WITH BACKER
 ROD AND SEALANT)**

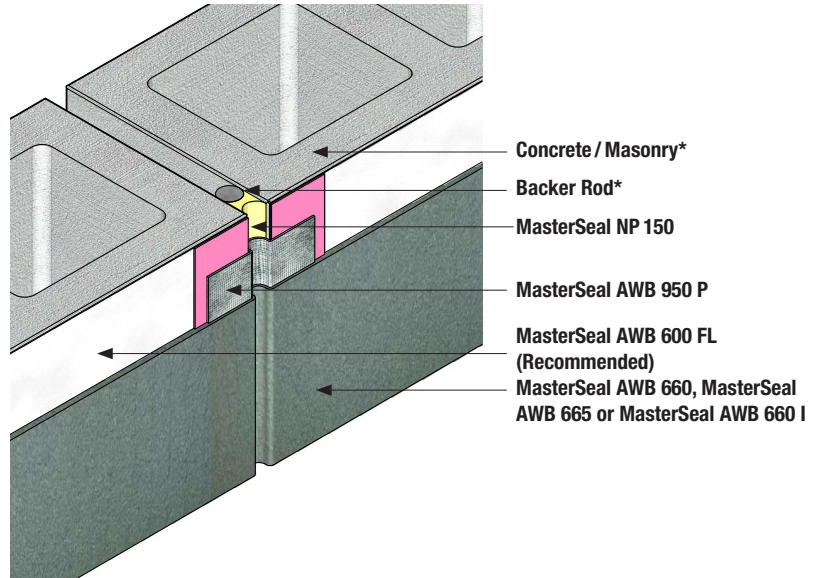

NOTES

- Ensure continuity of air/water-resistive barrier is maintained.
- Ensure a pinhole-free application of MasterSeal AWB 660 or MasterSeal AWB 665 or MasterSeal AWB 660 I is achieved.
- MasterSeal AWB 971 FIB or MasterSeal AWB 970 FIB application is optional at rough opening.
- For more information, reference the MasterSeal AWB 970 FIB Application Guidelines for Flashing Rough Openings on Concrete and Masonry technical bulletin.

TYPICAL ROUGH OPENING TREATMENT

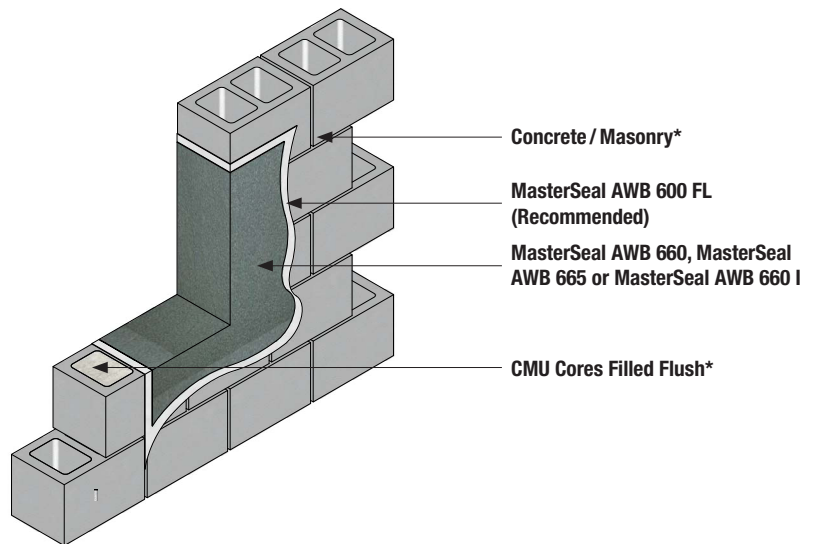

* By Others

TYPICAL PENETRATION THROUGH WALL CONSTRUCTION

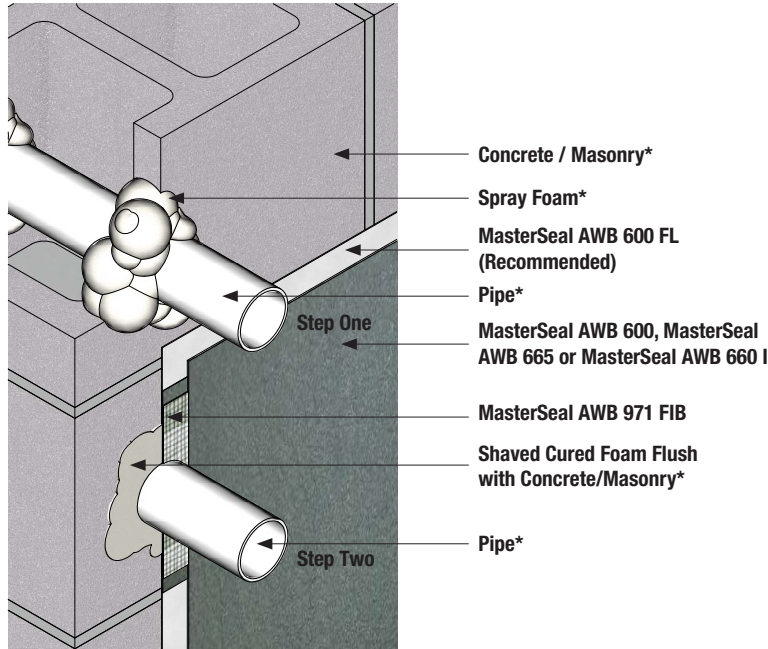

NOTES

- Ensure spray foam is low expansion.
- Embed MasterSeal AWB 971 FIB in MasterSeal AWB 660, MasterSeal AWB 665 or MasterSeal AWB 660 I

TYPICAL PENETRATION THROUGH WALL CONSTRUCTION (FABRIC ONLY)

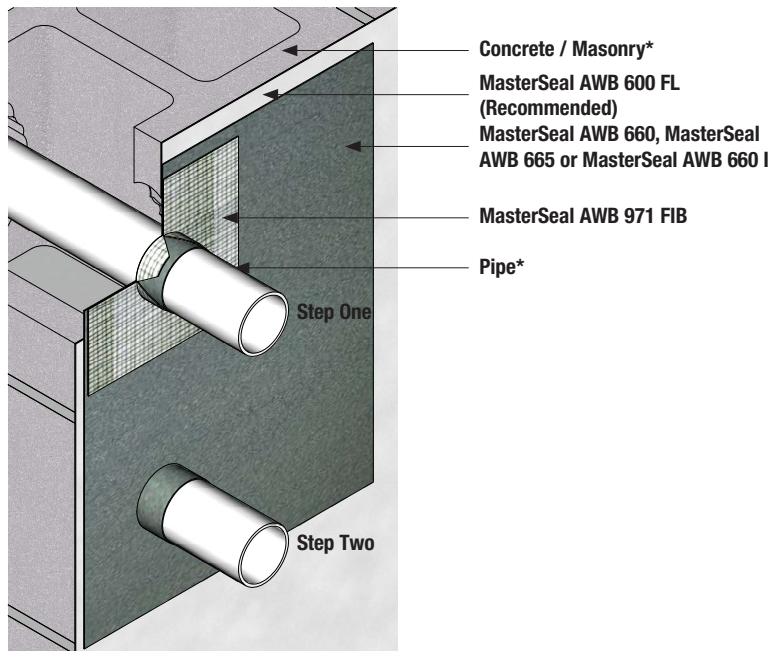

NOTES

- Cut a square piece of MasterSeal AWB 971 FIB large enough to extend past the pipe by 2" in each direction.
- At the center of the square piece of MasterSeal AWB 971 FIB, pierce a small hole with a blade or scissors.
- With a blade or scissors, cut an "X". Turn the square about 45° and cut another X. The center point of both "X"s will be the point you pierced previously.
- Insert the pipe through the newly cut square so it is centered with a minimum of 2" on each side with the cut flaps point outward. The square should be flush with the Concrete/Masonry, See Step 1.
- Embed the MasterSeal AWB 971 FIB in MasterSeal AWB 660, MasterSeal AWB 665 or MasterSeal AWB 660 I and coat the flaps around the pipe, See Step 2.
- Wrap a 1" strip of MasterSeal AWB 971 FIB embedded in MasterSeal AWB 660, MasterSeal AWB 665 or MasterSeal AWB 660 I around the flaps.

* By Others

NOTES

- Recessed or protruding wood bucks require special consideration.
- Ensure all blocking joints receive a full treatment of MasterSeal AWB and MasterSeal AWB 971 FIB.
- For more information, reference the MasterSeal AWB Application Guidelines for Flashing Rough Openings on Concrete and Masonry technical bulletin.

**TYPICAL ROUGH OPENING TREATMENT
 WITH BLOCKING AND MASTERSEAL AWB 971 FIB**

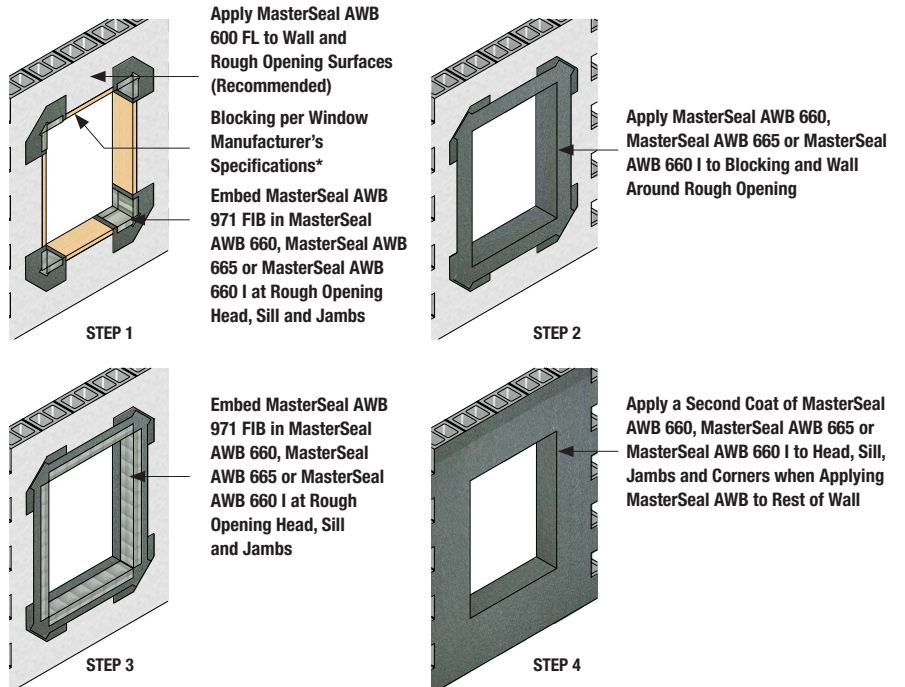

NOTES

- Recessed or protruding wood bucks require special consideration.
- Ensure all blocking joints receive a full treatment of MasterSeal AWB and MasterSeal AWB 971 FIB.
- For more information, reference the MasterSeal AWB Application Guidelines for Flashing Rough Openings on Concrete and Masonry technical bulletin.

**TYPICAL ROUGH OPENING TREATMENT
 WITH BLOCKING AND MASTERSEAL AWB 970 FIB**

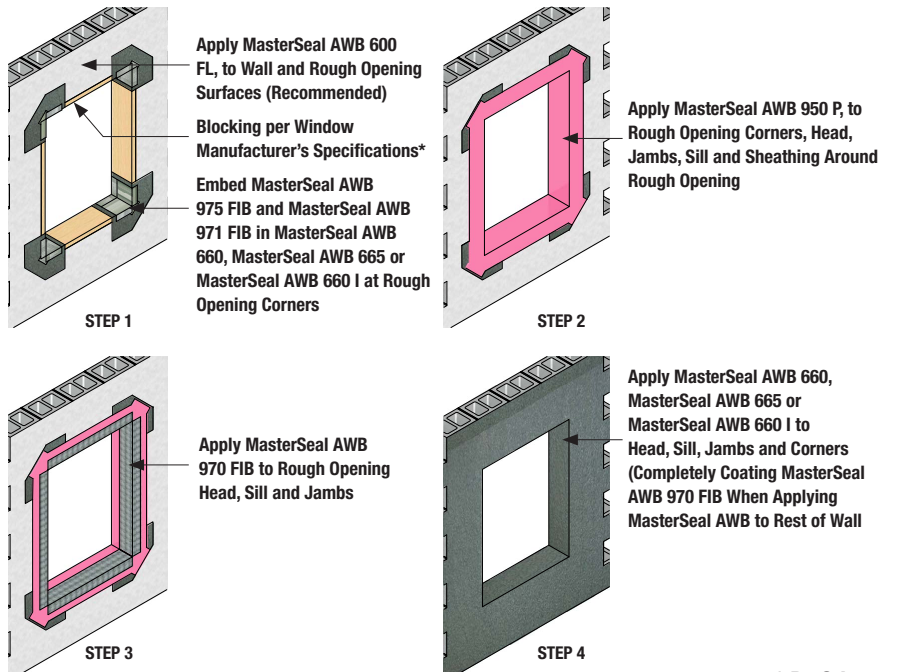

* By Others

TYPICAL TERMINATION AT GRADE MASONRY VENEER

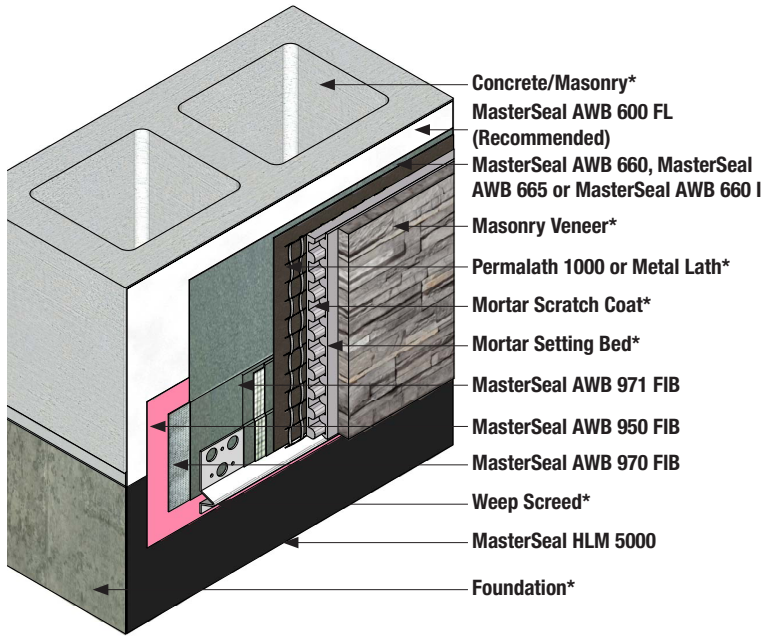

NOTES

- Embed Sheathing Fabric in MasterSeal AWB 660, MasterSeal AWB 665 or MasterSeal AWB 660 I.
- Paper backed lath can be used in lieu of slip sheet.

TYPICAL EIFS ABUTMENT TO BRICK W/ CONTINUOUS INSULATION

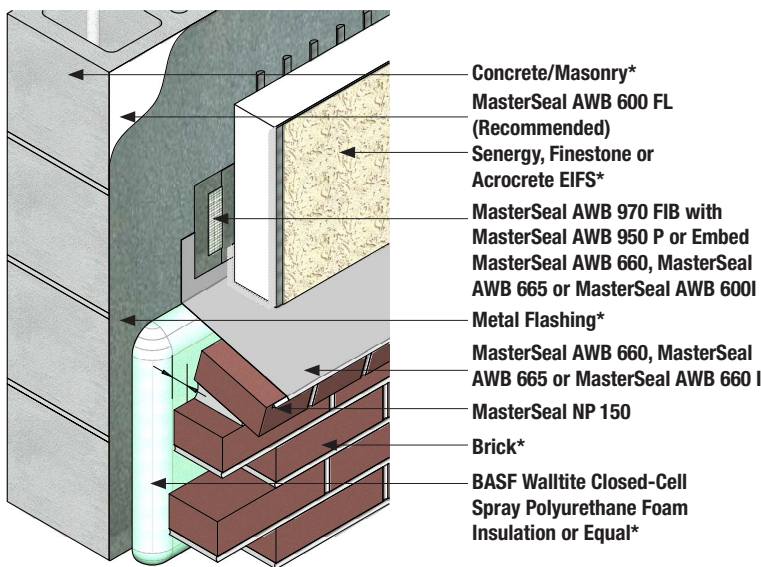

NOTES

- Embed MasterSeal AWB 971 FIB in MasterSeal AWB 600 I, MasterSeal AWB 665 or MasterSeal AWB 660 I.
- Up to 12" of EPS thickness can be used with BASF EIFS.

* By Others

NOTES

- Air space between masonry /concrete and brick per design (not shown).
- Extend self-adhered through wall Flashing Membrane flashing vertically up the wall to 203 mm (8") minimum height.

**TYPICAL TERMINATION AT FOUNDATION WITH BRICK
 INCORPORATING NOTES: TWF - TERMINATION BAR**

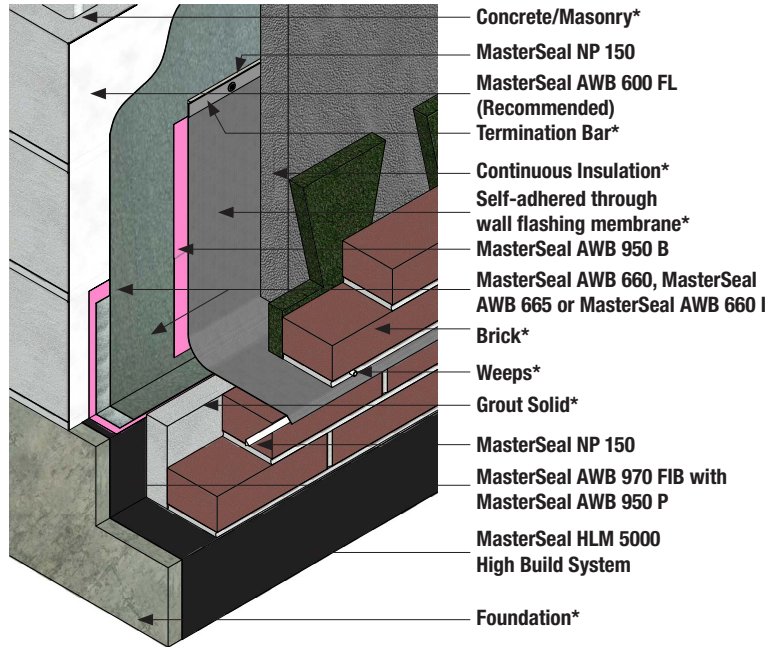

NOTES

- Air space between masonry /concrete and brick per design (not shown).
- Extend self-adhered through wall Flashing Membrane flashing vertically up the wall to 203 mm (8") minimum height.

**TYPICAL TERMINATION AT FOUNDATION WITH BRICK
 INCORPORATING MASTERSEAL AWB 970 FIB**

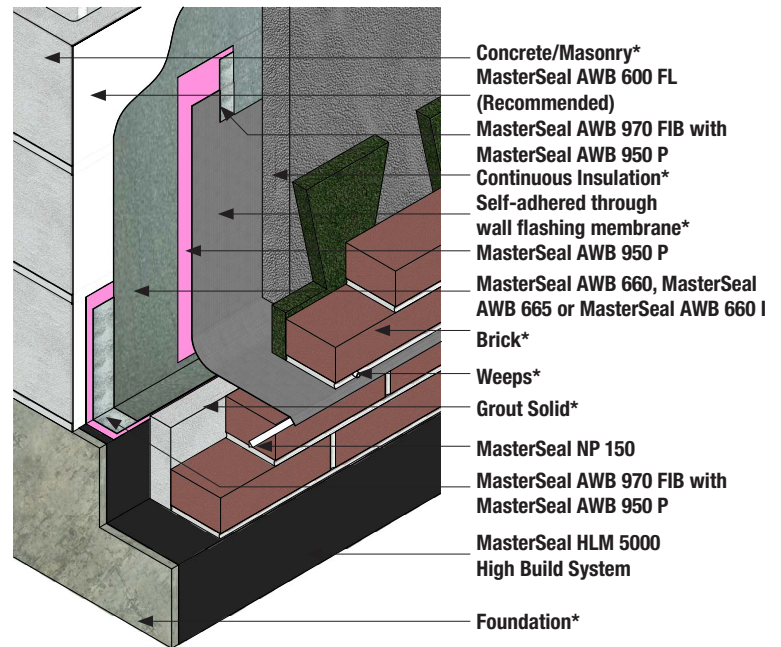

* By Others

TYPICAL INSIDE CORNER

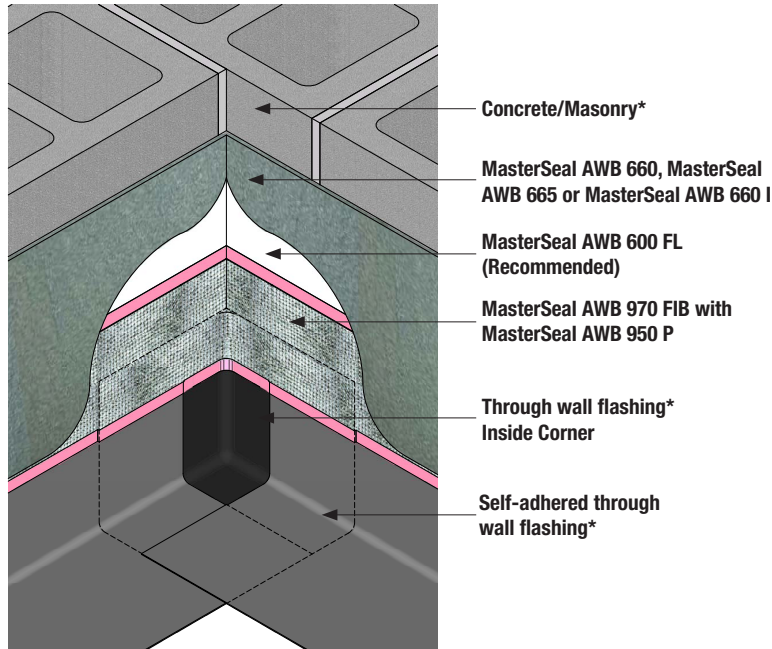

NOTES

- Set through wall flashing* Inside Corner in MasterSeal NP 150 Sealant.
- Lap self-adhered through wall flashing membrane* at least 2" onto Inside Corner.
- Apply a bead of MasterSeal NP 150 sealant between self-adhered through wall flashing* and Inside Corner to create an airtight and watertight seal.
- A termination bar and MasterSeal NP 150 sealant can be used instead of MasterSeal AWB 970 FIB (See AWRB-CMU-11).
- Center MasterSeal AWB 970 FIB so half of the width covers self-adhered through wall flashing* and half covers the CMU substrate.

Visit the website (www.master-buildersolutions.basf.us) for a four step expanded version of this detail.

TYPICAL OUTSIDE CORNER

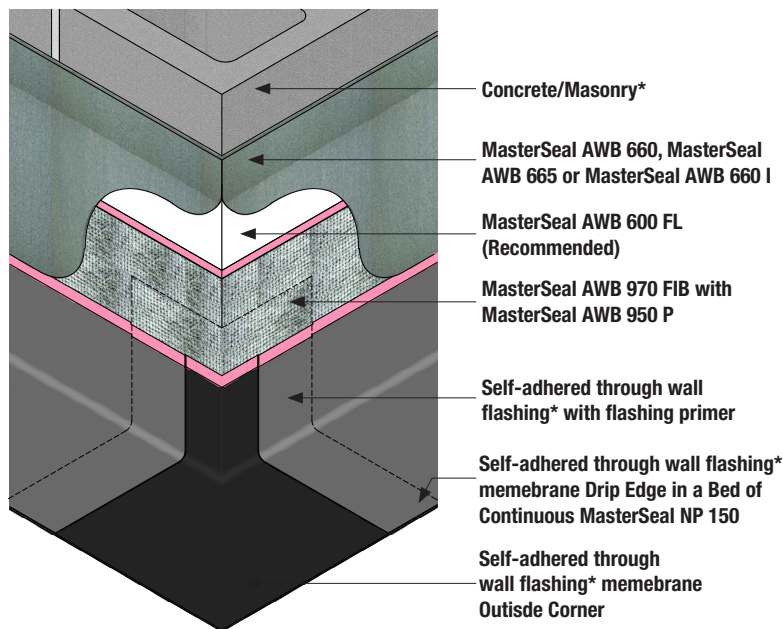

NOTES

- Set through wall flashing* Outside Corner in MasterSeal NP 150 Sealant.
- Extend self-adhered through wall flashing membrane* vertically up the wall 8" (not to scale)
- Apply a bead of MasterSeal NP 150 sealant between self-adhered through wall flashing* and Outside Corner to create an airtight and watertight seal.
- Self-adhered through wall flashing can be installed over MasterSeal AWB 600 FL (shown), MasterSeal AWB 660, MasterSeal AWB 665 or MasterSeal AWB 660 I
- Center MasterSeal AWB 970 FIB so half of the width covers self-adhered through wall flashing membrane* and half covers the gypsum sheathing.

- Lap self-adhered through wall flashing membrane* a minimum of 2" over Outside Corner

Visit the website (www.master-buildersolutions.basf.us) for a four step expanded version of this detail.

* By Others

NOTES

TYPICAL INSIDE CORNER CHANGE IN SUBSTRATE

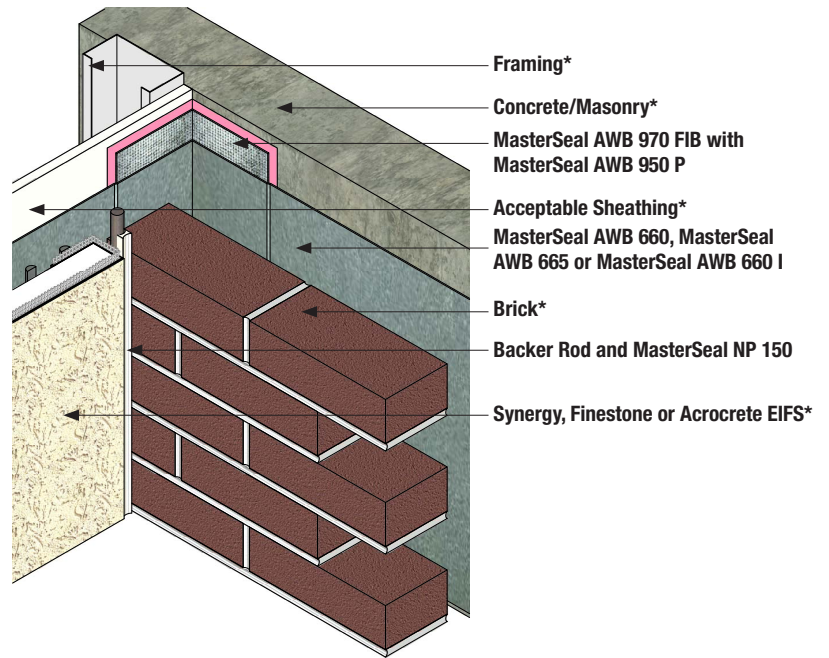

**TYPICAL TERMINATION AT FLOORLINE BRICK
 SHELF ANGLE**

NOTES

- Air space between masonry/concrete and brick per design (not shown).
- Do not apply self-adhered through wall flashing* to uncoated block; MasterSeal AWB 660, MasterSeal AWB 665, MasterSeal AWB 600 I or MasterSeal AWB 600 FL are acceptable.
- Protect self-adhered through wall flashing membrane* from overspray.

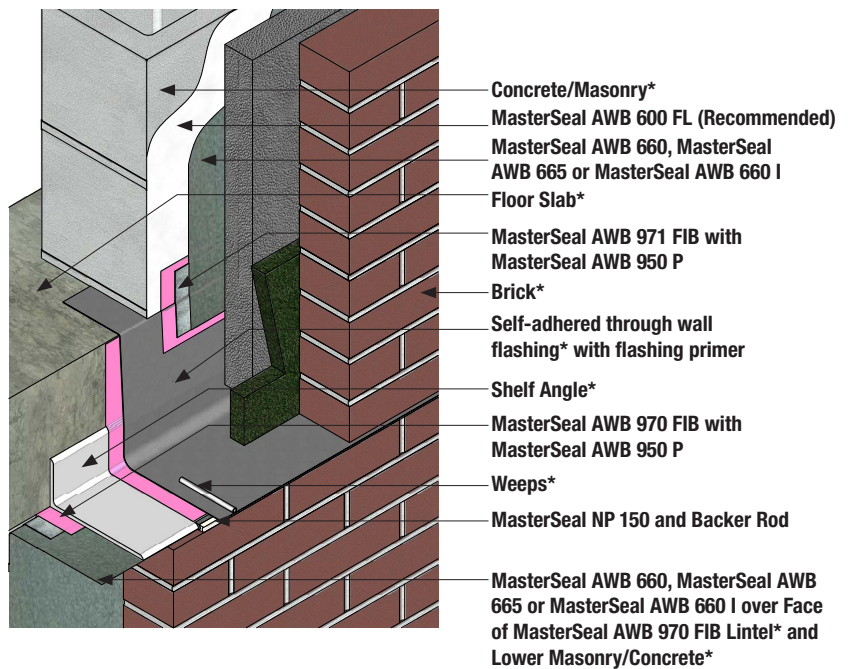

* By Others

TYPICAL THROUGH WALL FLASHING AT HEAD

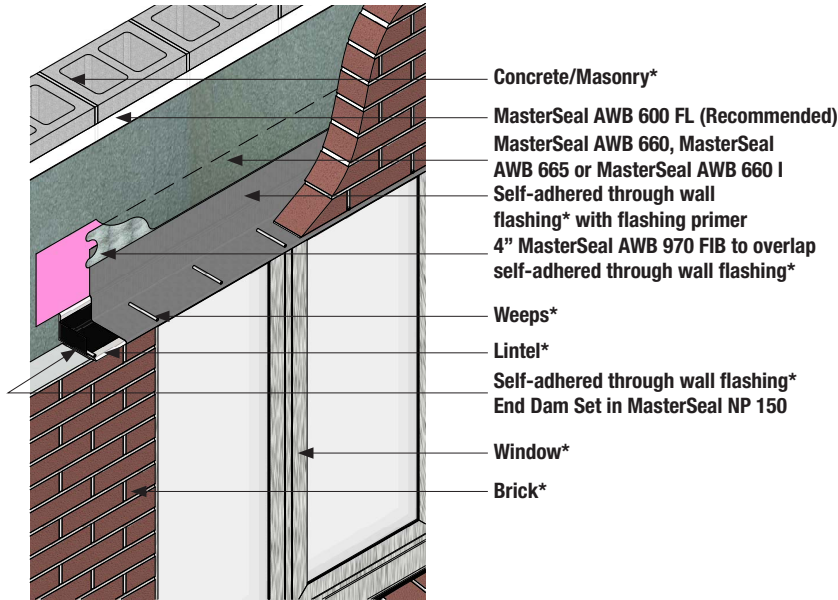

NOTES

- Air space between masonry /concrete and brick per design.
- Center MasterSeal AWB 970 FIB so half of the width covers self-adhered through wall flashing membrane* and half covers the primed substrate.
- Self-adhered through wall flashing membrane* can be folded to create an end dam. Ensure that seams are sealed with MasterSeal NP 150.
- If MasterSeal AWB is applied before self-adhered through wall flashing membrane*, use MasterSeal AWB 970 FIB and MasterSeal AWB 660, MasterSeal AWB 665 or MasterSeal AWB 660 I to seal the top edge.

Visit the website (www.master-buildersolutions.basf.us) for a four step expanded version of this detail.

TYPICAL WINDOW JAMB

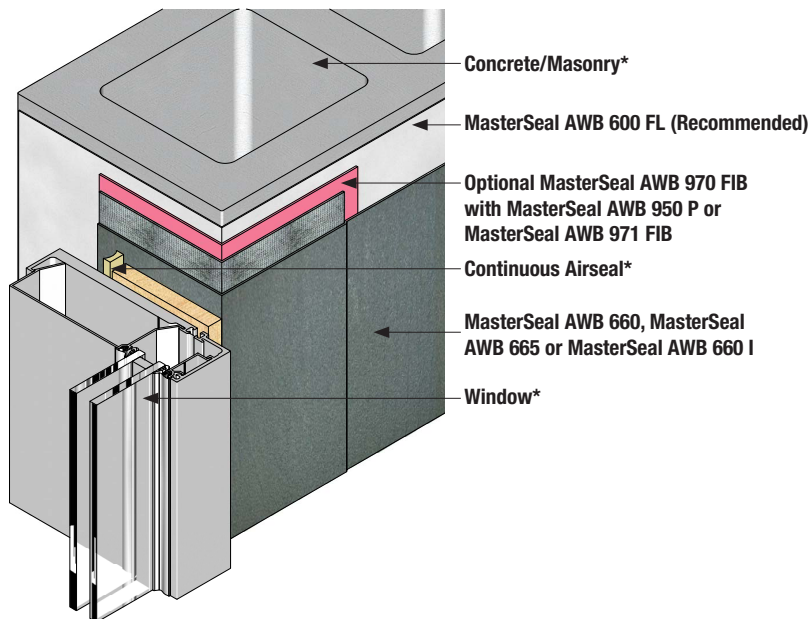

NOTES

- If blocking is installed prior to MasterSeal AWB application, it shall be treated as a rough opening; verify adhesion before proceeding.
- Either MasterSeal AWB 970 FIB with MasterSeal AWB 950 P or MasterSeal AWB 971 FIB can be used. See AWRB-CMU-04, AWRB-CMU-07 and AWRB-CMU-08.

* By Others

NOTES

- Embed MasterSeal AWB 971 FIB in MasterSeal AWB 660 or MasterSeal AWB 665 or MasterSeal AWB 660 I.
- Provide end dams at flashing terminations.
- If blocking is installed prior to MasterSeal AWB application, it shall be treated as a rough opening; verify adhesion before proceeding.
- Either MasterSeal AWB 970 FIB with MasterSeal AWB 950 P or MasterSeal AWB 971 FIB can be used. See AWRB-CMU-04, AWRB-CMU-07 and AWRB-CMU-08.

TYPICAL WINDOW HEAD

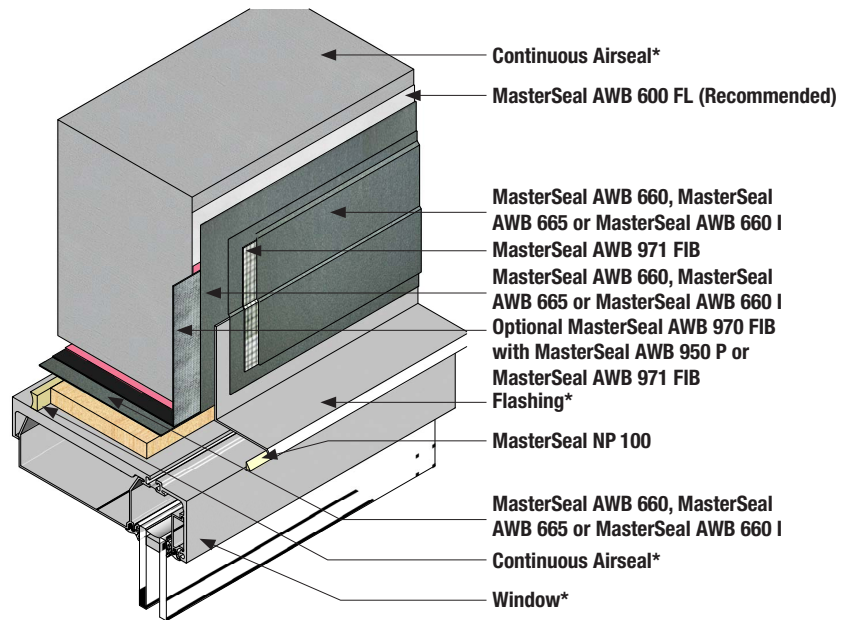

NOTES

- Install end/back dams as required.
- If blocking is installed prior to MasterSeal AWB 660, MasterSeal AWB 665 or MasterSeal AWB 660 I application, it shall be treated as a rough opening; verify adhesion before proceeding.
- Either MasterSeal AWB 970 FIB with MasterSeal AWB 950 P or MasterSeal AWB 971 FIB can be used. See AWRB-CMU-04, AWRB-CMU-07 and AWRB-CMU-08.
- Fill CMU cores solid flush.

TYPICAL WINDOW SILL

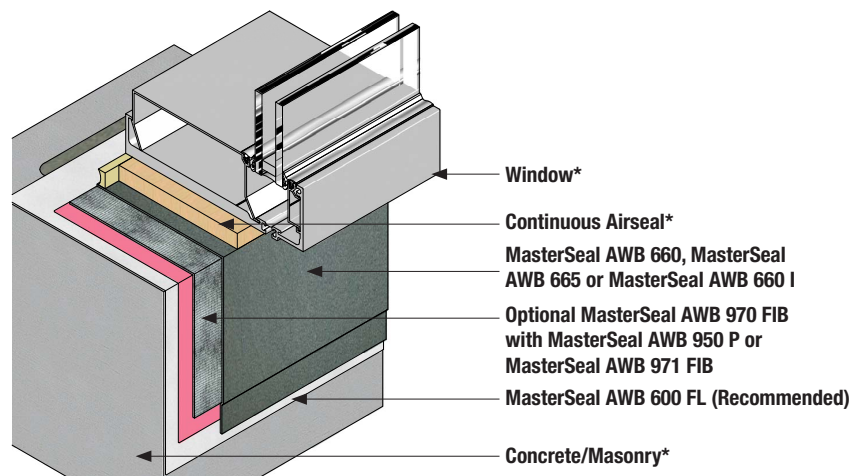

* By Others

TYPICAL ROOF EDGE OR PARAPET CAP FLASHING

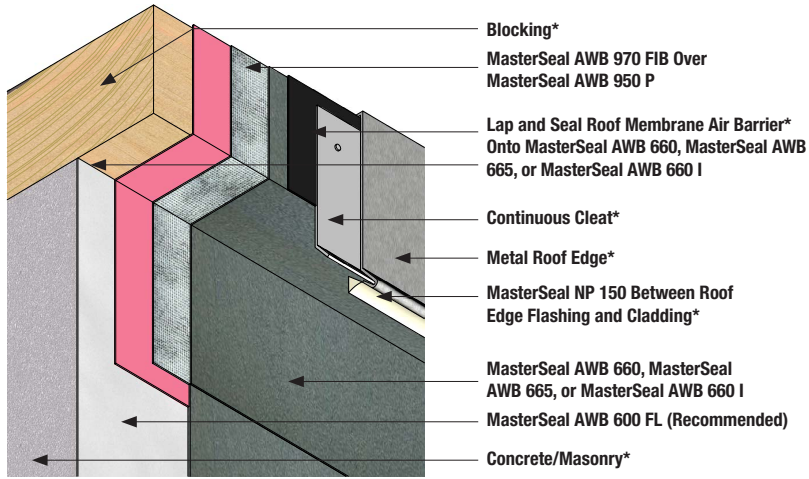

* By Others

NOTES

- Either MasterSeal AWB 970 FIB with MasterSeal AWB 950 P or MasterSeal AWB 971 FIB can be used to provide an air/water-resistive barrier at transition of sheathing to blocking.
- Avoid solvent-based adhesives/primers where roofing laps MasterSeal AWB.

HEALTH , SAFETY AND ENVIRONMENTAL

Read, understand and follow all Safety Data Sheets and product label information for this product prior to use. The SDS can be obtained by visiting www.master-builders-solutions.basf.us, e-mailing your request to basfbcsst@basf.com or calling 1(800) 433-9517. Use only as directed. For medical emergencies only, call ChemTrec® 1(800)424-9300.

LIMITED WARRANTY NOTICE

BASF warrants this product to be free from manufacturing defects and to meet the technical properties on the current Technical Data Guide, if used as directed within shelf life. Satisfactory results depend not only on quality products but also upon many factors beyond our control. BASF MAKES NO OTHER WARRANTY OR GUARANTEE, EXPRESS OR IMPLIED, INCLUDING WARRANTIES OF MERCHANTABILITY OR FITNESS FOR A PARTICULAR PURPOSE WITH RESPECT TO ITS PRODUCTS. The sole and exclusive remedy of Purchaser for any claim concerning this product, including but not limited to, claims alleging breach of warranty, negligence, strict liability or otherwise, is the replacement of product or refund of the purchase price, at the sole option of BASF. Any claims concerning this product must be received in writing within one (1) year from the date of shipment and any claims not presented within that period are waived by Purchaser. BASF WILL NOT BE RESPONSIBLE FOR ANY SPECIAL, INCIDENTAL, CONSEQUENTIAL (INCLUDING LOST PROFITS) OR PUNITIVE DAMAGES OF ANY KIND.

Purchaser must determine the suitability of the products for the intended use and assumes all risks and liabilities in connection therewith. This information and all further technical advice are based on BASF's present knowledge and experience. However, BASF assumes no liability for providing such information and advice including the extent to which such information and advice may relate to existing third party intellectual property rights, especially patent rights, nor shall any legal relationship be created by or arise from the provision of such information and advice. BASF reserves the right to make any changes according to technological progress or further developments. The Purchaser of the Product(s) must test the product(s) for suitability for the intended application and purpose before proceeding with a full application of the product(s). Performance of the product described herein should be verified by testing and carried out by qualified experts.

